



# Heavy Industry Products



Energy Absorption • Vibration Isolation • Motion Control

Heavy Duty (HD) Series Shock Absorbers  
Heavy Industry (HI) Series Buffers  
Jarret Series Dampers

**ENIDINE**

An **IMC** Company

# HEAVY INDUSTRY PRODUCTS



## Applications:

- Amusement ride emergency stops
- Transportation safety stops
- Ladle transfer cars
- Coil upenders/downenders
- Rolling mill chock separators
- Furnace slab bumpers
- Hot strip mill down-coiler
- Re-heat furnace entry end shock absorber
- Gantry/Stacker Cranes



# Table of Contents

## Product Selection

<b>Company Overview</b> .....	1	<b>General</b>
<b>New Technologies and Enhancements</b> .....	2	
<b>Theory of Energy Absorption</b> .....	3-4	
<b>Sizing Examples</b> .....	5-8	

## Energy Absorption Products

<b>HD/HDA Series (Heavy Duty Shock Absorbers)</b>		<b>HD/HDA</b>
Overview .....	9-10	
Adjustment Techniques .....	11	
Ordering Information .....	12	
HD/HDA Technical Data, Accessories .....	13-27	
Notes .....	28	
<b>HI Series (Heavy Industry Buffers)</b>		<b>HI</b>
Overview .....	29	
Ordering Information .....	30	
HI Technical Data, Accessories .....	31-32	
<b>Jarret Series</b>		<b>JT</b>
Overview .....	33	
Visco-elastic Technology Information .....	34	
BC1N, BC5 and LR Technical Data/Application Worksheets .....	35-42	
Application Worksheet .....	43	

Enidine, a preferred source for energy absorption and vibration isolation solutions, offers a full range of Heavy Duty (HD) and Heavy Industry (HI) products, each designed to protect equipment from large impacts in applications where consistent deceleration and safety is required.

Need Assistance? Enidine is ready to answer your questions, feel free to contact us at:

**Phone:** Toll Free - 1.800.852.8508  
Direct - 1.716.662.1900

**Fax:** General - 1.716.662.1909  
Industrial - 1.716.662.0406

**Email:** [industrialsales@enidine.com](mailto:industrialsales@enidine.com)

**Online:** [www.enidine.com](http://www.enidine.com)





With its world headquarters located in Orchard Park, New York, USA, **ENIDINE Incorporated** is a world leader in the design and manufacture of standard and custom energy absorption and vibration isolation product solutions within the Industrial, Aerospace, Defense, Marine and Rail markets. Product ranges include shock absorbers, gas springs, rate controls, air springs, wire rope isolators, heavy industry buffers and emergency stops. With facilities strategically located throughout the world and in partnership with our vast global network of distributors, Enidine Incorporated continues to strengthen its presence within marketplace.

Founded in 1966, Enidine Incorporated now has close to 600 employees located throughout the globe in the United States, Germany, France, Japan, China and Korea. With a team of professionals in engineering, computer science, manufacturing, production and marketing our employees provide our customers the very best in service and application solutions.

***“Enidine is widely recognized as the preferred source for energy absorption and vibration isolation products.”***

From Original Equipment Manufacturers (OEM) to aftermarket applications, Enidine offers a unique combination of product selection, engineering excellence and technical support to meet even the toughest energy absorption application requirements.

Global Manufacturing and Sales Facilities offer our customers:

- ***Highly Trained Distribution Network***
- ***State-of-the Art Engineering Capabilities***
- ***Custom Solution Development***
- ***Customer Service Specialists***
- ***Multiple Open Communication Channels***

If you are unsure whether one of our standard products meets your requirements, feel free to speak with one of our technical representatives **toll-free at 1-800-852-8508**, or contact us via **e-mail at [industrialsales@enidine.com](mailto:industrialsales@enidine.com)**.

#### **Products/Engineering/Technical Support**

Enidine continually strives to provide the widest selection of shock absorbers and rate control products in the global marketplace. Through constant evaluation and testing, we bring our customers the most cost effective products with more features, greater performance and improved ease of use.

# New Technologies and Enhancements

## Research and Development

Enidine engineers continue to monitor and influence trends in the motion control industry, allowing us to remain at the forefront of new energy absorption and vibration isolation product development.

Our experienced engineering team has designed custom solutions for a wide variety of challenging applications, including automated warehousing systems and shock absorbers for hostile industrial environments such as glass manufacturing, among others. These custom application solutions have proven to be critical to our customers' success. Let Enidine engineers do the same for you.



*Custom designs are not an exception at Enidine, they are an integral part of our business. Should your requirements fit outside of our standard product range, Enidine engineers can assist in developing special finishes, components, hybrid technologies and new designs to ensure a "best-fit" product solution customized to your exact specifications.*

## Global Service and Support

Enidine offers its customers a global network of customer service staff technical sales personnel that are available to assist you with all of your application needs.

- Operating with lean manufacturing and cellular production, Enidine produces higher quality custom and standard products with greater efficiency and within shorter lead times.
- An authorized Global Distribution Network is trained regularly by ENIDINE staff on new products and services ensuring they are better able to serve you.
- Global operations in United States, Germany, France, China, Japan and Korea.
- A comprehensive, website full of application information, technical data, sizing examples and information to assist in selecting the product that's right for you.

Our website also features a searchable worldwide distributor lookup to help facilitate fast, localized service. Contact us today for assistance with all of your application needs.

## New Products and Services

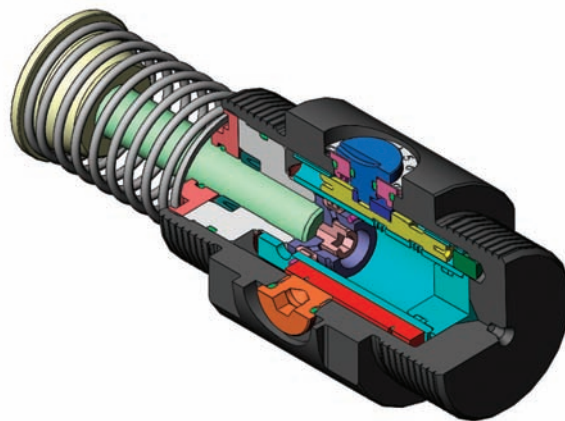

A talented engineering staff works to design and maintain the most efficient energy absorption product lines available today, using the latest engineering tools:

- **Solid Modeling**
- **3-D CAD Drawings**
- **3-D Soluble Support Technology**
- **Finite Element Analysis**
- **Complete Product Verification Testing Facility**

New product designs get to market fast because they can be fully developed in virtual environments before a prototype is ever built. This saves time and lets us optimize the best solution using real performance criteria.



*Our global customer service and technical sales departments are available to assist you find the solution that's right for your application needs. Call us at 1.800.852.8508 or e-mail us at [industrialsales@enidine.com](mailto:industrialsales@enidine.com) and let us get started today.*

As companies strive to increase productivity by operating machinery at higher speeds, often the results are increased noise, damage to machinery/products, and excessive vibration. At the same time, safety and machine reliability are decreased. A variety of products are commonly used to solve these problems. However, they vary greatly in effectiveness and operation. Typical products used include rubber bumpers, springs, cylinder cushions and shock absorbers. The following illustrations compare how the most common products perform:

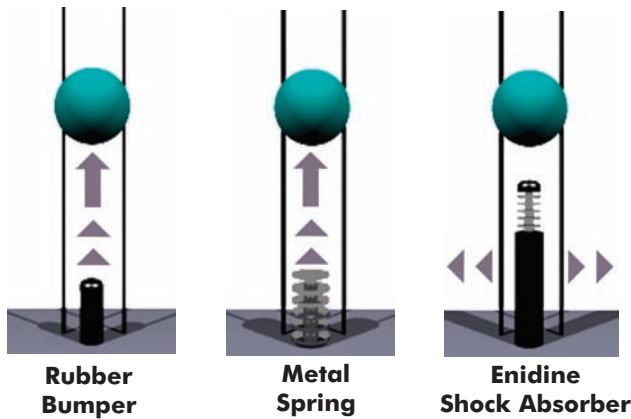

All moving objects possess kinetic energy. The amount of energy is dependent upon weight and velocity. A mechanical device that produces forces diametrically opposed to the direction of motion must be used to bring a moving object to rest.

**Rubber bumpers and springs**, although very inexpensive, have an undesirable recoil effect. Most of the energy absorbed by these at impact is actually stored. This stored energy is returned to the load, producing rebound and the potential for damage to the load or machinery. Rubber bumpers and springs initially provide low resisting force which increases with the stroke.

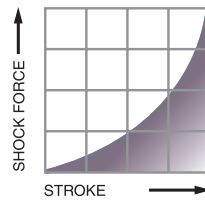

**Cylinder cushions** are limited in their range of operation. Most often they are not capable of absorbing energy generated by the system. By design, cushions have a relatively short stroke and operate at low pressures resulting in very low energy absorption. The remaining energy is transferred to the system, causing shock loading and vibration.

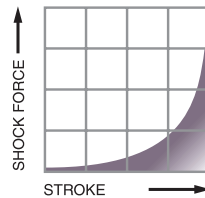

**Shock absorbers** provide controlled, predictable deceleration. These products work by converting kinetic energy to thermal energy. More specifically, motion applied to the piston of a hydraulic shock absorber pressurizes the fluid and forces it to flow through restricting orifices, causing the fluid to heat rapidly. The thermal energy is then transferred to the cylinder body and harmlessly dissipated to the atmosphere.

The advantages of using shock absorbers include:

- 1. Longer Machine Life** – The use of shock absorbers significantly reduces shock and vibration to machinery. This eliminates machinery damage, reduces downtime and maintenance costs, while increasing machine life.
- 2. Higher Operating Speeds** – Machines can be operated at higher speeds because shock absorbers control or gently stop moving objects. Therefore, production rates can be increased.
- 3. Improved Production Quality** – Harmful side effects of motion, such as noise, vibration and damaging impacts, are moderated or eliminated so the quality of production is improved. Therefore, tolerances and fits are easier to maintain.
- 4. Safer Machinery Operation** – Shock absorbers protect machinery and equipment operators by offering predictable, reliable and controlled deceleration. They can also be designed to meet specified safety standards, when required.
- 5. Competitive Advantage** – Machines become more valuable because of increased productivity, longer life, lower maintenance costs and safer operation.

## Automotive vs. Industrial Shock Absorbers

It is important to understand the differences that exist between the standard automotive-style shock absorber and the industrial shock absorber.



The automotive style employs the defllective beam and washer method of orificing. Industrial shock absorbers utilize single orifice, multi-orifice and metering pin configurations. The automotive type maintains a damping force which varies in direct proportion to the velocity of the piston, while the damping force in the industrial type varies in proportion to the square of the piston velocity. In addition, the damping force of the automotive type is independent of the stroke position while the damping force associated with the industrial type can be designed either dependent or independent of stroke position.

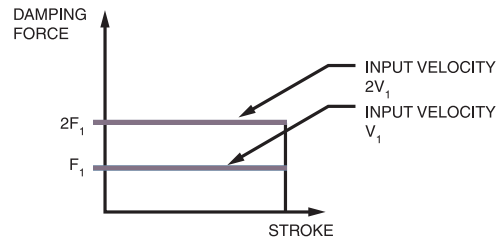

AUTOMOTIVE TYPE SHOCK ABSORBER

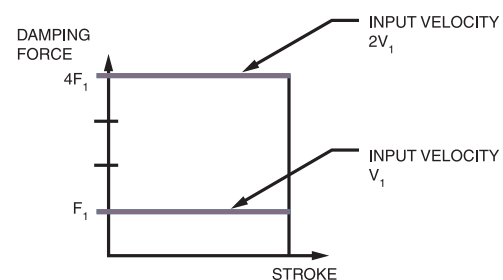

INDUSTRIAL TYPE SHOCK ABSORBER

Equally as important, automotive-style shock absorbers are designed to absorb only a specific amount of input energy. This means that, for any given geometric size of automotive shock absorber, it will have a limited amount of absorption capability compared to the industrial type.

This is explained by observing the structural design of the automotive type and the lower strength of materials commonly used. These materials can withstand the lower pressures commonly found in this type. The industrial shock absorber uses higher strength materials, enabling it to function at higher damping forces.

### Adjustment Techniques

A properly adjusted shock absorber safely dissipates energy, reducing damaging shock loads and noise levels. For optimum adjustment setting see useable adjustment setting graphs. Watching and "listening" to a shock absorber as it functions aids in proper adjustment.



To correctly adjust a shock absorber, set the adjustment knob at zero (0) prior to system engagement. Cycle the mechanism and observe deceleration of the system.

If damping appears too soft (unit strokes with no visual deceleration and bangs at end of stroke), move indicator to next largest number. Adjustments must be made in gradual increments to avoid internal damage to the unit (e.g., adjust from 0 to 1, not 0 to 4).

Increase adjustment setting until smooth deceleration or control is achieved and negligible noise is heard when the system starts either to decelerate or comes to rest.

When abrupt deceleration occurs at the beginning of the stroke (banging at impact), the adjustment setting must be moved to a lower number to allow smooth deceleration.

If the shock absorber adjustment knob is set at the high end of the adjustment scale and abrupt deceleration occurs at the end of the stroke, a larger unit may be required.

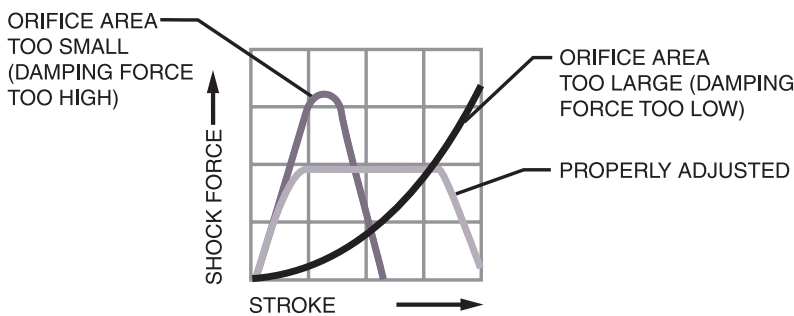

### Shock Absorber Performance When Weight or Impact Velocity Vary

When conditions change from the original calculated data or actual input, a shock absorber's performance can be greatly affected, causing failure or degradation of performance. Variations in input conditions after a shock absorber has been installed can cause internal damage, or at the very least, can result in unwanted damping performance. Variations in weight or impact velocity can be seen by examining the following energy curves:

**Varying Impact Weight:** Increasing the impact weight (impact velocity remains unchanged), without reorificing or readjustment will result in increased damping force at the end of the stroke. Figure 1 depicts this undesirable bottoming peak force. This force is then transferred to the mounting structure and impacting load.

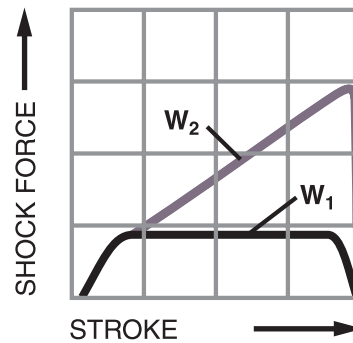

Figure 1

**Varying Impact Velocity:** Increasing impact velocity (weight remains the same) results in a radical change in the resultant shock force. Shock absorbers are velocity conscious products; therefore, the critical relationship to impact velocity must be carefully monitored. Figure 2 depicts the substantial change in shock force that occurs when the velocity is increased. Variations from original design data or errors in original data may cause damage to mounting structures and systems, or result in shock absorber failure if the shock force limits are exceeded.

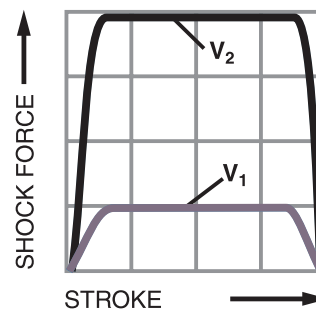

Figure 2

# Shock Absorber Sizing Examples

## Typical Shock Absorber Applications

### Overview

#### SYMBOLS

a = Acceleration (in./sec.<sup>2</sup>)(m/s<sup>2</sup>)  
 A = Width (in.)(m)  
 B = Thickness (in.)(m)  
 C = Number of cycles per hour  
 d = Cylinder bore diameter (in.)(mm)  
 D = Distance (in.)(m)  
 E<sub>K</sub> = Kinetic energy (in-lbs.)(Nm)  
 E<sub>T</sub> = Total energy per cycle  
 (in-lbs./c)(Nm/c), E<sub>K</sub> + E<sub>W</sub>  
 E<sub>T</sub>C = Total energy to be absorbed per  
 hour (in-lbs./hr)(Nm/hr)  
 E<sub>W</sub> = Work or drive energy (in-lbs.)(Nm)  
 F<sub>D</sub> = Propelling force (lbs.)(N)  
 F<sub>P</sub> = Shock force (lbs.)(N)  
 H = Height (in.)(m)  
 Hp = Motor rating (hp)(kw)  
 L = Length (in.)(m)  
 P = Operating pressure (psi)(bar)  
 S = Stroke of shock absorber (in.)(m)  
 t = Time (sec.)  
 T = Torque (in-lbs.)(Nm)  
 V = Impact velocity (in./sec.)(m/s)  
 W = Weight (lbs.)(Kg)

#### USEFUL FORMULAS

##### 1. To Determine Shock Force

$$F_P = \frac{E_T}{S \times .85}$$

##### 2. To Determine Impact Velocity

A. If there is no acceleration (V is constant)  
 (e.g., load being pushed by hydraulic cylinder or motor driven.)

$$V = \frac{D}{t}$$

B. If there is acceleration.  
 (e.g., load being pushed by air cylinder)

$$V = \frac{2 \times D}{t}$$

##### 3. To Determine Propelling Force Generated by Electric Motor

$$F_D = \frac{19,800 \times Hp}{V} \quad F_D = \frac{30,000 \times Hp}{V} \text{ (metric)}$$

##### 4. To Determine Propelling Force of Pneumatic or Hydraulic Cylinders

$$F_D = .7854 \times d^2 \times P \quad F_D = 0,07854 \times d^2 \times P \text{ (metric)}$$

##### 5. Free Fall Applications

A. Find Velocity for a Free Falling Weight:  
 $V = \sqrt{772 \times H}$      $V = \sqrt{19,6 \times H}$  (metric)  
 B. Kinetic Energy of Free Falling Weight:  
 $E_K = W \times H$

##### 6. Deceleration and G Load

A. To Determine Approximate G Load with a Given Stroke

$$G = \frac{F_P - F_D}{W} \quad G = \frac{F_P - F_D}{kg \times 9,81} \text{ (metric)}$$

B. To Determine the Approximate Stroke with a Given G Load (Conventional Damping Only)

$$S = \frac{E_K}{GW \times .85 - .15 F_D}$$

NOTE: Constants are printed in **bold**.

The following examples are shown using Imperial formulas and units of measure.

### Shock Absorbers

#### EXAMPLE 1:

##### Vertical Free Falling Weight

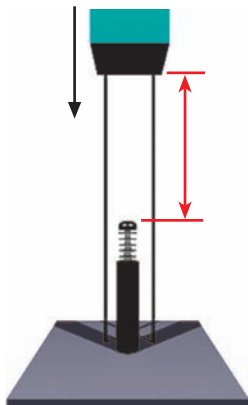

##### STEP 1: Application Data

(W) Weight = 5,000 lbs.  
 (H) Height = 20 in.  
 (C) Cycles/Hr = 2

##### STEP 2: Calculate kinetic energy

$E_K = W \times H$   
 $E_K = 5,000 \times 20 = 100,000$  in-lbs.

Assume Model HD 2.0 x 10 is adequate (Page 15).

##### STEP 3: Calculate work energy

$E_W = W \times S$   
 $E_W = 5,000 \times 10$   
 $E_W = 50,000$  in-lbs.

##### STEP 4: Calculate total energy per cycle

$E_T = E_K + E_W$   
 $E_T = 100,000 + 50,000$   
 $E_T = 150,000$  in-lbs./c

##### STEP 5: Calculate total energy per hour

$E_{T}C = E_T \times C$   
 $E_{T}C = 150,000 \times 2$   
 $E_{T}C = 300,000$  in-lbs./hr

##### STEP 6: Calculate impact velocity and confirm selection

$V = \sqrt{772 \times H}$   
 $V = \sqrt{772 \times 20}$   
 $V = 124$  in./sec.

Model HD 2.0 x 10 is adequate.

#### EXAMPLE 2:

##### Free Moving Load Down an Inclined Plane

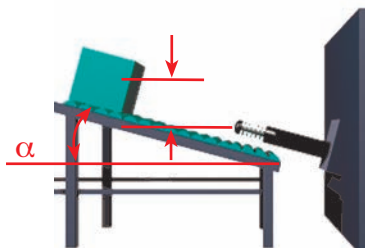

##### STEP 1: Application Data

(W) Weight = 2,000 lbs.  
 (H) Height = 8 in.  
 (α) Angle of incline = 30°  
 (C) Cycles/Hr = 60

##### STEP 2: Calculate kinetic energy

$E_K = W \times H$   
 $E_K = 2,000 \times 8$   
 $E_K = 16,000$  in-lbs.

Assume Model HD 1.5 x 2 is adequate (Page 13).

##### STEP 3: Calculate work energy

$F_D = W \times \sin \alpha$   
 $F_D = 2,000 \times .5$   
 $F_D = 1,000$  lbs.  
 $E_W = F_D \times S$   
 $E_W = 1,000 \times 2$   
 $E_W = 2,000$  in-lbs.

##### STEP 4: Calculate total energy per cycle

$E_T = E_K + E_W$   
 $E_T = 16,000 + 2,000$   
 $E_T = 18,000$  in-lbs./c

##### STEP 5: Calculate total energy per hour

$E_{T}C = E_T \times C$   
 $E_{T}C = 18,000 \times 60$   
 $E_{T}C = 1,080,000$  in-lbs./hr

##### STEP 6: Calculate impact velocity and confirm selection

$V = \sqrt{772 \times H}$   
 $V = \sqrt{772 \times 8} = 79$  in./sec.

Model HD 1.5 x 2 is adequate.

# Shock Absorber Sizing Examples

## Typical Shock Absorber Applications

**EXAMPLE 3:**  
**Horizontal Moving Load**

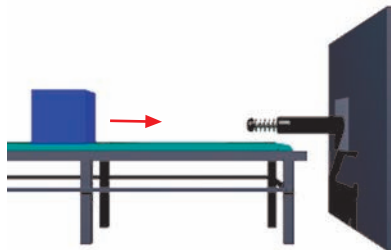

**STEP 1: Application Data**

(W) Weight = 20,000 lbs.  
(V) Velocity = 20 in./sec.  
(C) Cycles/Hr = 4

**STEP 2: Calculate kinetic energy**

$$E_K = \frac{W}{772} \times V^2$$

$$E_K = \frac{20,000}{772} \times 20^2$$

$$E_K = 10,364 \text{ in-lbs.}$$

Assume Model HD 1.5 x 2 is adequate (Page 13).

**If there is no additional drive force proceed to step 4 and  $E_w = 0$ . If the application is driven by a cylinder, proceed to step 3a. If the application is driven by a motor proceed to step 3b.**

**STEP 3a: Calculate work energy:**

(d) Cylinder bore diameter = 6 in.  
(P) Cylinder pressure = 80 psi  
 $F_D = .7854 \times d^2 \times P$   
 $F_D = .7854 \times 6^2 \times 80 \text{ psi}$   
 $F_D = 2,262 \text{ lbs.}$

$$E_w = F_D \times S$$

$$E_w = 2,262 \times 2$$

$$E_w = 4,524 \text{ in-lbs.}$$

**STEP 3b: Calculate work energy:**

(Hp) Motor Horsepower = 5 Hp  
 $F_D = \frac{19,800 \times \text{Hp}}{V}$

$$F_D = \frac{19,800 \times 5}{20}$$

$$F_D = 4,950 \text{ in-lbs.}$$

$$E_w = F_D \times S$$

$$E_w = 4,950 \times 2$$

$$E_w = 9,900 \text{ in-lbs.}$$

**STEP 4: Calculate total energy per cycle**

**Note: Using Calculations from 3a**

$$E_T = E_K + E_w$$

$$E_T = 10,364 + 4,524$$

$$E_T = 14,888 \text{ in-lbs.}$$

**STEP 5: Calculate total energy per hour**

$$E_T C = E_T \times C$$

$$E_T C = 14,888 \times 4$$

$$E_T C = 59,552 \text{ in-lbs./hr}$$

Model HD 1.5 x 2 is adequate.

# Shock Absorber Sizing Examples

## Typical Shock Absorber and Crane Applications

Overview

Crane A		Per Buffer
Propelling Force Crane	lbs.	
Propelling Force Trolley	lbs.	
Weight of Crane	lbs.	
Weight of Trolley	lbs.	
Distance $X_{min}$	in.	
Distance $X_{max}$	in.	
Distance $Y_{min}$	in.	
Distance $Y_{max}$	in.	
Crane Velocity	in./sec.	
Trolley Velocity	in./sec.	

Crane B		Per Buffer
Propelling Force Crane	lbs.	
Propelling Force Trolley	lbs.	
Weight of Crane	lbs.	
Weight of Trolley	lbs.	
Distance $X_{min}$	in.	
Distance $X_{max}$	in.	
Distance $Y_{min}$	in.	
Distance $Y_{max}$	in.	
Crane Velocity	in./sec.	
Trolley Velocity	in./sec.	

Crane C		Per Buffer
Propelling Force Crane	lbs.	
Propelling Force Trolley	lbs.	
Weight of Crane	lbs.	
Weight of Trolley	lbs.	
Distance $X_{min}$	in.	
Distance $X_{max}$	in.	
Distance $Y_{min}$	in.	
Distance $Y_{max}$	in.	
Crane Velocity	in./sec.	
Trolley Velocity	in./sec.	

**Please note:**  
Unless instructed otherwise, Enidine will always calculate with:

- 100% velocity  $v$ , and
- 100% propelling force  $F_D$

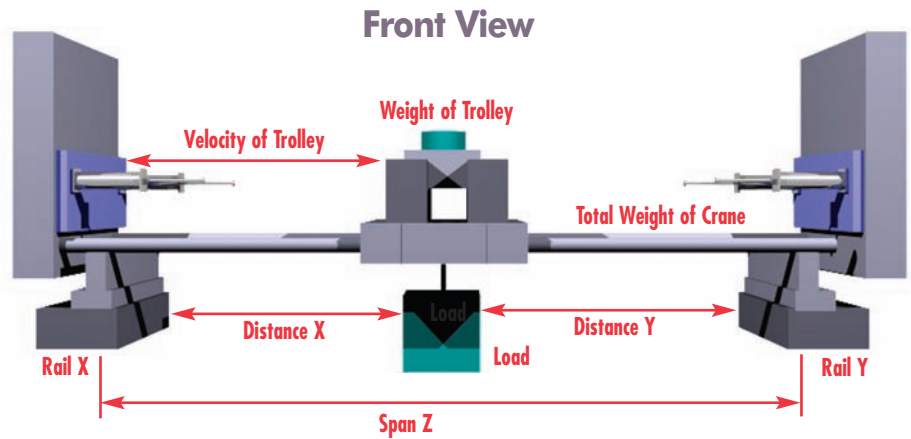

### Plan Views

#### Application 1

**Crane A against Solid Stop**

Velocity:

$$V_r = V_A$$

Impact weight per buffer:

$$W_D = \frac{W}{2}$$

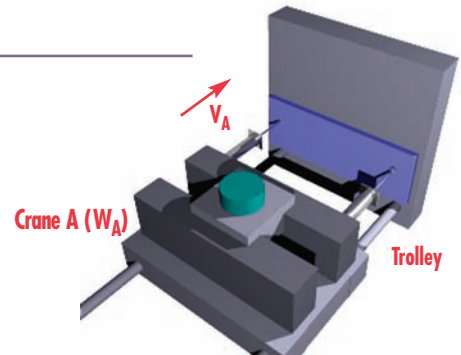

#### Application 2

**Crane A against Crane B**

Velocity:

$$V_r = V_A + V_B$$

Impact weight per buffer:

$$W_D = \frac{W_A \cdot W_B}{W_A + W_B} \div 2$$

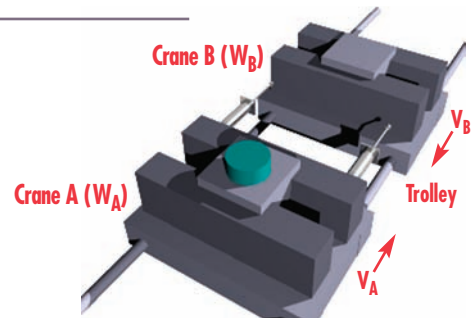

#### Application 3

**Crane B against Crane C**

Velocity:

$$V_r = \frac{V_B + V_C}{2}$$

Impact weight per buffer:

$$W_D = \frac{W_B \cdot W_C}{W_B + W_C}$$

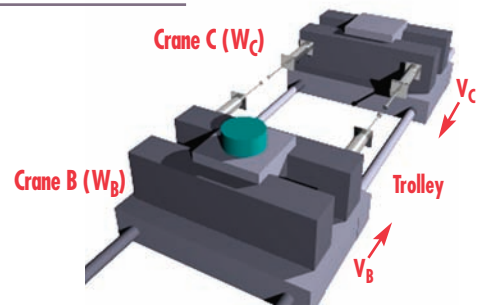

#### Application 4

**Crane C against Solid Stop with Buffer**

Velocity:

$$V_r = \frac{V_C}{2}$$

Impact weight per buffer:

$$W_D = W_C$$

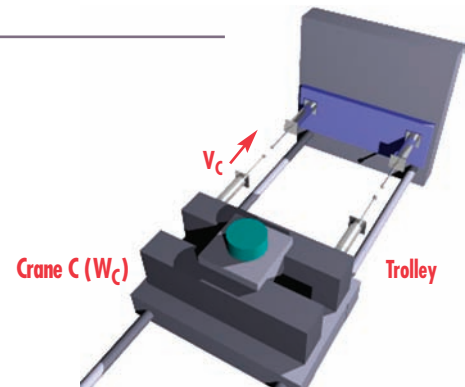

# Shock Absorber Sizing Examples

## Typical Shock Absorber and Crane Applications

### Overview

#### Calculation Example for Harbor Cranes as Application 1

#### Given Values

#### Determination of the Maximum Impact Weight $W_{Dmax}$ per Buffer

#### Determine Size of Shock Absorber for Crane

#### Determine Size of Shock Absorber for Trolley

Please note that this example is not based on any particular standard. The slung load can swing freely, and is therefore not taken into account in the calculation.

<p><b>Total Weight of Crane:</b> 837,750 lbs.</p> <p><b>Weight of Trolley:</b> 99,200 lbs.</p> <p><b>Span:</b> <math>z = 3,940</math> in.</p> <p><b>Trolley Impact Distance:</b> <math>x = 3,540</math> in.</p> <p><b>Crane Velocity:</b> <math>V_{Crane} = 60</math> in./sec.</p> <p><b>Required Stroke:</b> 24 in.</p> <p><b>Trolley Velocity:</b> <math>V_{Trolley} = 160</math> in./sec.</p> <p><b>Required Stroke:</b> 40 in.</p>	
<p>Bridge Weight per Rail = <math>\frac{\text{crane weight}_{total} - \text{trolley weight}}{2}</math></p> <p>Bridge Weight per Rail = <math>\frac{837,750 \text{ lbs.} - 99,200 \text{ lbs.}}{2} = 369,275</math> lbs.</p> <p><math>W_{Dmax} = \text{Bridge Weight per Rail} + \text{Trolley Weight in Impact Position}</math></p> <p><math>W_{Dmax} = 369,275 \text{ lbs.} + \frac{(99,200 \text{ lbs.} \cdot 3,540 \text{ in.})}{3,940 \text{ in.}}</math></p> <p><b><math>W_{Dmax} = 458,404</math> lbs.</b></p>	
<p><math>E_K = \frac{W_{Dmax}}{772} \cdot V_r^2</math></p> <p><math>E_K = \frac{458,404 \text{ lbs.}}{772} \cdot (60 \text{ in./sec.})^2</math></p> <p><b><math>E_K = 2,137,635</math> in-lbs.</b></p> <p>Selecting for required 24-inch stroke:  <b>HD 5.0 x 24, maximum shock force ca. 104,786 lbs = <math>F_s = \frac{E_K}{s \cdot \eta}</math></b></p>	<p><math>V_r = V_A</math> Application 1</p> <p><math>E_K = \text{Kinetic Energy}</math></p> <p><math>\eta = \text{Efficiency}</math></p>
<p><math>W_D = \text{Trolley Weight per Shock Absorber}</math></p> <p><math>W_D = \frac{99,200 \text{ lbs.}}{2}</math></p> <p><b><math>W_D = 49,600</math> lbs.</b></p> <p><math>E_K = \frac{W_D}{772} \cdot V_r^2</math></p> <p><math>E_K = \frac{49,600 \text{ lbs.}}{772} \cdot (160 \text{ in./sec.})^2</math></p> <p><b><math>E_K = 1,644,767</math> in-lbs.</b></p> <p>Selecting for required 40-inch stroke:  <b>HD 4.0 x 40, maximum shock force ca. 48,376 lbs. = <math>F_s = \frac{E_K}{s \cdot \eta}</math></b></p>	<p><math>V_r = V_A</math> Application 1</p>



Enidine Heavy Duty Series (HD/HDA) large-bore hydraulic shock absorbers protect equipment from large impacts in applications such as automated storage and retrieval systems, as well as overhead bridge and trolley cranes.

They are available in a wide variety of stroke lengths and damping characteristics to increase equipment life and meet stringent deceleration requirements.

### HD Series

Custom-orificed design accommodates specified damping requirements. Computer generated output performance simulation is used to optimize the orifice configuration. Available in standard bore dimensions of up to 6 in. (150mm) and strokes over 60 in. (1525mm).

### HDA Series

Adjustable units enable the user to modify shock absorber resistance to accommodate load velocity variations, with strokes up to 12in. (305mm). Standard adjustable configurations available. Special bore sizes and strokes for both HD and HDA Series models are available upon request.

## Features and Benefits

- Compact design smoothly and safely decelerates large energy capacity loads up to 8,000,000 in.-lbs. per cycle (903 880 Nm)
- Engineered to meet OSHA, AISE, CMMA and other safety specifications such as DIN and FEM.
- Internal air charged bladder accumulator replaces mechanical return springs, providing shorter overall length and reduced weight.
- Wide variety of optional configurations including bellows, clevis mounts and safety cables.
- Available in standard adjustable or custom-orificed non-adjustable models.
- Zinc plated external components provide enhanced corrosion protection.
- Epoxy painting and special rod materials are available for use in highly corrosive environments.
- All sizes are fully field repairable.
- Piston rod extension sensor systems available for reuse safety requirements.
- Incorporating optional fluids and seal packages can expand standard operating temperature range from 15°F to 140°F to -30°F to 210°F (-10°C to 60°C) to (-35°C to 100°C)

# Heavy Duty Shock Absorbers

HD, HDA Series

## Enidine Heavy Duty (HD) Large-bore Series Shock Absorbers

### Overview

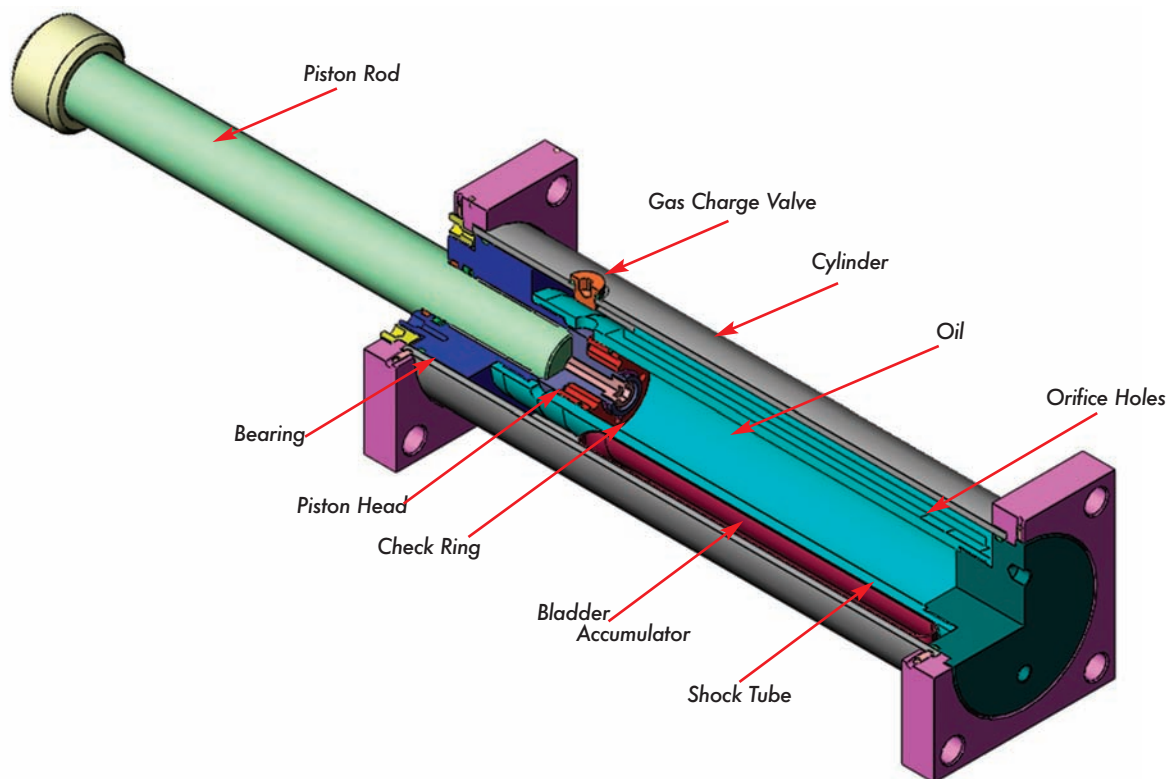

The Enidine HD/HDA Series is a large-bore, multi-orifice family of shock absorbers which incorporates a double cylinder arrangement with space between the concentric shock tube and cylinder, and a series of orifice holes drilled down the length of the shock tube wall.

During piston movement, the check ring is seated and oil is forced through the orifices in the shock tube wall, into the gas charged bladder/accumulator area, and behind the piston head. The orifice area decreases as the piston moves and closes the orifice holes. The bladder/accumulator is also compressed by the oil during the compression stroke, which compensates for the fluid displaced by the piston rod during compression.

During repositioning, the pressure from the bladder/accumulator pushes the piston rod outward. This unseats the check ring and permits oil to flow rapidly through the piston head into the front of the shock tube. The unique gas-charged bladder accumulator replaces mechanical return springs, decreasing overall product size and weight.

The HD/HDA Series can provide conventional, progressive or self-compensating damping. Their compact, heavy-duty design safely and effectively decelerates large moving loads, with energy capacities of up to 8,000,000 in.-lbs. per cycle (903 880 Nm).

### HD/HDA Sizing Examples

1. Determine load weight (lbs. or Kg), impact velocity (in./sec or m/s), propelling force (lbs. or N) if any, cycles per hour and stroke (in. or mm) required.
2. Calculate total energy per cycle (in.-lbs./c or Nm/c) and total energy per hour (in.-lbs./hr or Nm/hr). Consult this catalog's sizing examples (pages 5-6) for assistance, if required.
3. Compare the calculated total energy per cycle (in.-lbs./c or Nm/c) and total energy per hour (in.-lbs./hr or Nm/hr), to the values listed in the HD/HDA Series Engineering Data charts. For HDA selection, the impact velocity must be below 130 in./sec. (3.3 m/s).
4. Select the appropriate HD/HDA Series model.

#### Example: Horizontal Application

- |                                     |                         |
|-------------------------------------|-------------------------|
| 1. Weight (W):                      | 55,000 lbs. (24 950 Kg) |
| Velocity (V):                       | 43 in./sec. (1,1 m/s)   |
| Propelling Force (F <sub>D</sub> ): | 6,700 lbs. (29 803 N)   |
| Cycles/Hour (C):                    | 10 cycles/hr            |
| Stroke (S):                         | 5 in. (127 mm)          |
2. Total Energy/Cycle (E<sub>T</sub>): 165,229 in.-lbs./c (18 6668 Nm/c)  
Total Energy/Hour (E<sub>T</sub>C): 1,652,290 in.-lbs./hr (18 6668 Nm/h)
  3. Compare total energy per cycle and total energy per hour to the HD/HDA Series Engineering Data charts (pages 13-27).
  4. Selection: HD 3.0 x 5 (HDA is not appropriate because maximum in.-lbs. per cycle (Nm per cycle) are exceeded).

### Useable Adjustment Setting Range

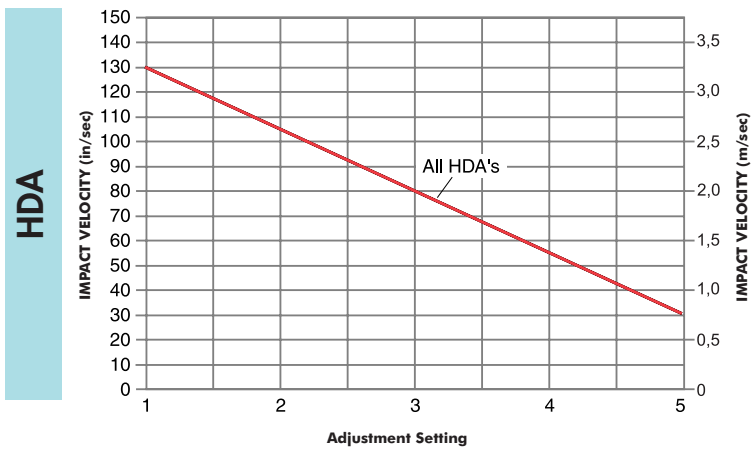

**Damping Force**  
Position 1 provides minimum damping force.  
Position 5 provides maximum damping force.

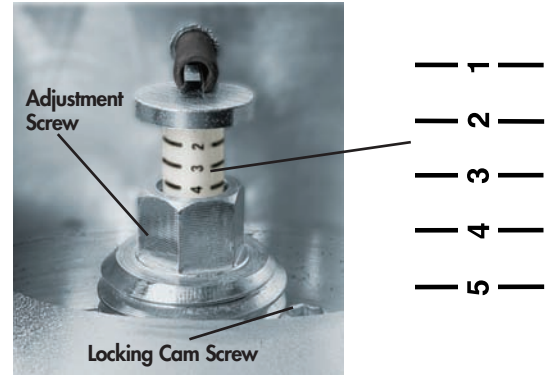

Adjustment is accomplished by turning the adjustment screw. Once the desired setting has been reached, lock in place by tightening the locking cam screw.

After properly sizing an HDA shock absorber, the useable range of adjustment settings can be determined:

1. Locate the intersection point of the application's impact velocity and the HDA model graph line.
2. The intersection is the maximum adjustment setting to be used. Adjustments exceeding this setting could overload the shock absorber.
3. The useable adjustment setting range is from setting 1 to the MAXIMUM adjustment setting as determined in step 2.

#### EXAMPLE: HDA Series

1. Impact Velocity: 80 in./sec. (2 m/s)
2. Intersection Point: Adjustment Setting 3
3. Useable Adjustment Setting Range: 1 to 3

### Optional Piston Rod Return Sensor

- Magnetic proximity sensor indicates complete piston rod return with 10-foot long cable.
- If complete piston rod does not return the circuit remains open. This can be used to trigger a system shut-off.
- Contact Enidine for other available sensor types.

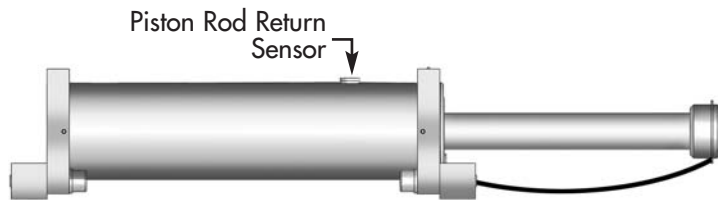

### Sensor Specifications

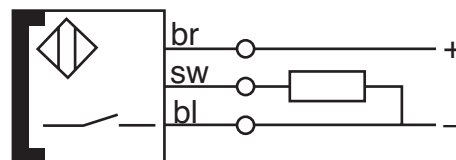

- Voltage 10 - 30V
- Load Current  $\leq$  200 mA
- Leakage Current  $\leq$  80 mA
- Load Capacitance  $\leq$  1.0 mF
- Ambient Temperature:  $-15^{\circ}$  to  $160^{\circ}$ F ( $-26^{\circ}$  to  $71^{\circ}$ C)

# Heavy Duty Series Shock Absorber

## HD/HDA Series

### Ordering Information

Typical mounting methods are shown below. Special mounting requirements can be accommodated upon request.



TM: Rear Flange Front Foot Mount

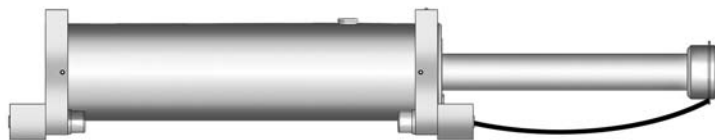

FM: Front and Rear Foot Mount  
Also shown is optional safety cable, typically used in overhead applications.



TF: Front and Rear Flanges



FF: Front Flange



CJ/CM: Clevis Mount



FR: Rear Flange

Note: Rear flange mounting not recommended for stroke lengths above 12 inches.

## Shock Absorbers

Note: HD models are custom-orificed, therefore all information must be provided to Enidine for unique part number assignment.

Example:

**4**

Select quantity

**HD 3.0 x 5**

Select HD (Non-Adjustable) or HDA (Adjustable) Catalog No. from Engineering Data Chart

**TM**

Select mounting method

- TM (Rear flange front foot mount)
- FM (Front and rear foot mount)
- TF (Front and rear flanges)
- FF (Front flange)
- FR (Rear flange)
- CJ (Imperial clevis mount)
- CM (Metric clevis mount)

**C**

Options

- C (Sensor cable)
- P (Sensor plug)
- SC (Safety cable)

### APPLICATION DATA

Required for HD models:

- Vertical or horizontal motion
- Weight
- Impact velocity
- Propelling force (if any)
- Cycles/Hr
- Other (temperature or other environmental conditions, safety standards, etc.)

HD 1.5 x 2 → HD 1.5 x 24 Series

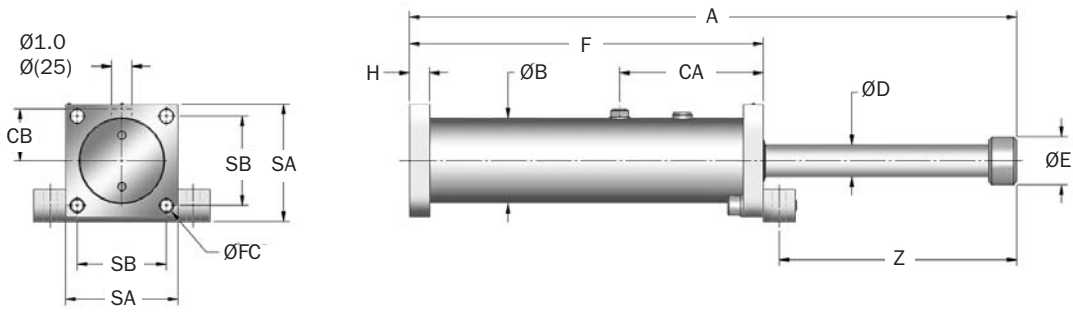

Note: For TF, FF and FR mounting, delete front foot and dimensions.

Catalog No./ Model	(S) Stroke in. (mm)	(E <sub>T</sub> ) Max. in.-lbs./cycle (Nm/cycle)	(E <sub>T-C</sub> ) Max. in.-lbs./hour (Nm/hr)	(F <sub>p</sub> ) Max. Shock Force lbs. (N)	Nominal Return Force lbs. (N)	Flange Dimensions			Model Weight (lbs.) (Kg)
						SA in. (mm)	SB in. (mm)	Rec. Bolt in. (mm)	
HD 1.5 x 2	2 (50)	27,000 (3 000)	1,590,000 (180 000)	15,750 (70 000)	63 (280)	4.7 (120)	3.5 (90)	1/2 (M12)	22 (10)
HD 1.5 x 4	4 (100)	53,000 (5 950)	3,160,000 (357 000)	15,750 (70 000)	63 (280)	4.7 (120)	3.5 (90)	1/2 (M12)	24 (12)
HD 1.5 x 6	6 (150)	79,000 (8 930)	4,742,000 (535 800)	15,750 (70 000)	63 (280)	4.7 (120)	3.5 (90)	1/2 (M12)	26 (12)
HD 1.5 x 8	8 (200)	106,000 (11 900)	6,319,000 (714 000)	15,750 (70 000)	63 (280)	4.7 (120)	3.5 (90)	1/2 (M12)	29 (13)
HD 1.5 x 10	10 (250)	132,000 (14 900)	7,426,000 (839 181)	15,750 (70 000)	63 (280)	4.7 (120)	3.5 (90)	1/2 (M12)	31 (14)
HD 1.5 x 12	12 (300)	158,000 (17 800)	8,315,000 (939 646)	15,750 (70 000)	63 (280)	4.7 (120)	3.5 (90)	1/2 (M12)	35 (16)
HD 1.5 x 14	14 (350)	184,000 (20 800)	9,187,000 (1 038 141)	15,750 (70 000)	63 (280)	4.7 (120)	3.5 (90)	1/2 (M12)	37 (17)
HD 1.5 x 16	16 (400)	180,000 (20 400)	10,076,000 (1 138 606)	13,500 (60 000)	63 (280)	4.7 (120)	3.5 (90)	1/2 (M12)	40 (18)
HD 1.5 x 18	18 (450)	162,000 (18 300)	9,717,000 (1 098 000)	10,750 (48 000)	63 (280)	4.7 (120)	3.5 (90)	1/2 (M12)	42 (19)
HD 1.5 x 20	20 (500)	146,000 (16 500)	8,761,000 (990 000)	8,750 (39 000)	63 (280)	4.7 (120)	3.5 (90)	1/2 (M12)	44 (20)
HD 1.5 x 24	24 (600)	126,000 (14 200)	7,540,000 (852 000)	6,250 (28 000)	63 (280)	4.7 (120)	3.5 (90)	1/2 (M12)	50 (23)

# Heavy Duty Series Shock Absorber

## HD/HDA Series

### Technical Data

HD 1.5 x 2 → HD 1.5 x 24 Series

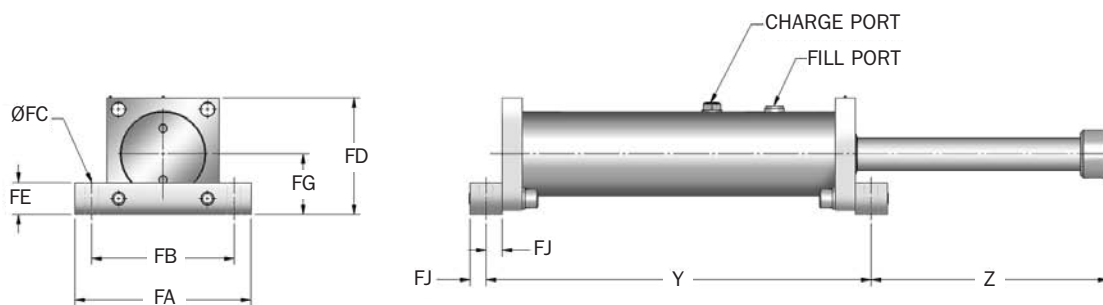

Note: For TF, FF and FR mounting, delete front foot and dimensions.

Catalog No./ Model	Foot Mount Dimensions									Charge Port Dimensions							
	A in. (mm)	B in. (mm)	D in. (mm)	E in. (mm)	F in. (mm)	H in. (mm)	Y in. (mm)	Z in. (mm)	FA in. (mm)	FB in. (mm)	FC in. (mm)	FD in. (mm)	FE in. (mm)	FG in. (mm)	FJ in. (mm)	CA in. (mm)	CB in. (mm)
HD 1.5 x 2	12.2 (310)	3.5 (90)	1.1 (28)	2.0 (50)	8.2 (208)	0.8 (20)	9.4 (240)	3.4 (86)	6.5 (165)	5.5 (140)	.55 (14)	4.9 (125)	1.3 (32)	2.5 (65)	.63 (16)	5.7 (144)	2.2 (56)
HD 1.5 x 4	16.1 (410)	3.5 (90)	1.1 (28)	2.0 (50)	10.2 (258)	0.8 (20)	11.4 (290)	5.3 (136)	6.5 (165)	5.5 (140)	.55 (14)	4.9 (125)	1.3 (32)	2.5 (65)	.63 (16)	5.7 (144)	2.2 (56)
HD 1.5 x 6	20.1 (510)	3.5 (90)	1.1 (28)	2.0 (50)	12.2 (308)	0.8 (20)	13.4 (340)	7.3 (186)	6.5 (165)	5.5 (140)	.55 (14)	4.9 (125)	1.3 (32)	2.5 (65)	.63 (16)	5.7 (144)	2.2 (56)
HD 1.5 x 8	24.1 (613)	3.5 (90)	1.1 (28)	2.0 (50)	14.2 (360)	0.8 (20)	15.4 (392)	9.3 (237)	6.5 (165)	5.5 (140)	.55 (14)	4.9 (125)	1.3 (32)	2.5 (65)	.63 (16)	5.7 (144)	2.2 (56)
HD 1.5 x 10	28.2 (715)	3.5 (90)	1.1 (28)	2.0 (50)	16.2 (411)	0.8 (20)	17.4 (443)	11.4 (288)	6.5 (165)	5.5 (140)	.55 (14)	4.9 (125)	1.3 (32)	2.5 (65)	.63 (16)	5.7 (144)	2.2 (56)
HD 1.5 x 12	32.2 (817)	3.5 (90)	1.1 (28)	2.0 (50)	18.2 (462)	0.8 (20)	19.4 (494)	13.4 (339)	6.5 (165)	5.5 (140)	.55 (14)	4.9 (125)	1.3 (32)	2.5 (65)	.63 (16)	5.7 (144)	2.2 (56)
HD 1.5 x 14	36.1 (918)	3.5 (90)	1.1 (28)	2.0 (50)	20.2 (512)	0.8 (20)	21.4 (544)	15.3 (390)	6.5 (154)	5.5 (140)	.55 (14)	4.9 (125)	1.3 (32)	2.5 (65)	.63 (16)	5.7 (144)	2.2 (56)
HD 1.5 x 16	40.1 (1 019)	3.5 (90)	1.1 (28)	2.0 (50)	22.2 (563)	0.8 (20)	23.4 (595)	17.3 (440)	6.5 (165)	5.5 (140)	.55 (14)	4.9 (125)	1.3 (32)	2.5 (65)	.63 (16)	5.7 (144)	2.2 (56)
HD 1.5 x 18	44.1 (1 121)	3.5 (90)	1.1 (28)	2.0 (50)	24.2 (614)	0.8 (20)	25.4 (646)	19.3 (491)	6.5 (165)	5.5 (140)	.55 (14)	4.9 (125)	1.3 (32)	2.5 (65)	.63 (16)	5.7 (144)	2.2 (56)
HD 1.5 x 20	48.2 (1 223)	3.5 (90)	1.1 (28)	2.0 (50)	26.2 (665)	0.8 (20)	27.4 (697)	21.4 (542)	6.5 (165)	5.5 (140)	.55 (14)	4.9 (125)	1.3 (32)	2.5 (65)	.63 (16)	5.7 (144)	2.2 (56)
HD 1.5 x 24	56.2 (1 427)	3.5 (90)	1.1 (28)	2.0 (50)	30.2 (767)	0.8 (20)	31.4 (799)	25.4 (644)	6.5 (165)	5.5 (140)	.55 (14)	4.9 (125)	1.3 (32)	2.5 (65)	.63 (16)	5.7 (144)	2.2 (56)

Notes: 1. HD shock absorbers will function satisfactorily at 5% of their maximum rated energy per cycle.

If less than these values, a smaller model should be specified.

- It is recommended that the customer consult Enidine for safety-related overhead crane applications.
- The energy data listed is for ideal linear impacts only. If side load conditions exist in the application, contact Enidine for sizing assistance.
- Rear flange mounting of 12 inch strokes and longer not recommended. Front and rear flange or foot mount configurations are recommended.
- Maximum cycle rate is 60 cycles/hr.
- For impact velocities over 180 in./sec. (4.5 m/s), consult factory.

HD 2.0 x 10 → HD 2.0 x 56 Series

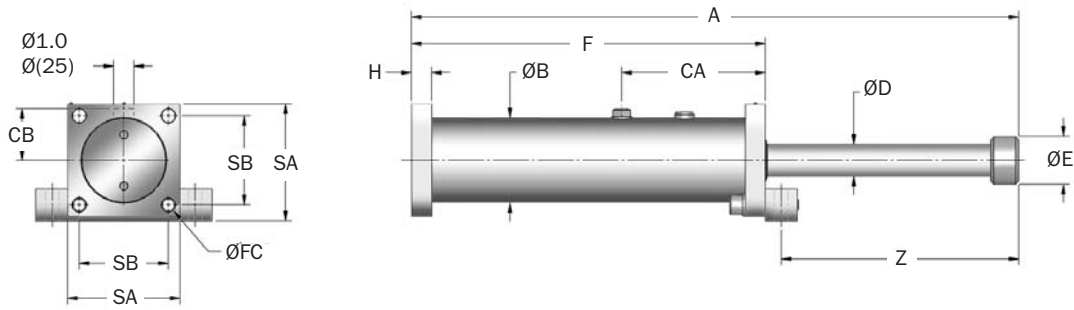

Note: For TF, FF and FR mounting, delete front foot and dimensions.

Catalog No./ Model	(S) Stroke in. (mm)	(E <sub>T</sub> ) Max. in.-lbs./cycle (Nm/cycle)	(E <sub>C</sub> ) Max. in.-lbs./hour (Nm/hr)	(F <sub>P</sub> ) Max. Shock Force lbs. (N)	Nominal Return Force lbs. (N)	Flange Dimensions			Model Weight (lbs.) (Kg)
						SA in. (mm)	SB in. (mm)	Rec. Bolt Size in. (mm)	
<b>HD 2.0 x 10</b>	10 (250)	212,000 (24 000)	9,403,000 (1 062 482)	25,000 (110 000)	100 (440)	5.5 (140)	4.4 (111)	5/8 (M16)	51 (23)
<b>HD 2.0 x 12</b>	12 (300)	248,000 (28 000)	10,490,000 (1 185 355)	25,000 (110 000)	100 (440)	5.5 (140)	4.4 (111)	5/8 (M16)	55 (25)
<b>HD 2.0 x 14</b>	14 (350)	290,000 (32 700)	11,577,000 (1 308 227)	25,000 (110 000)	100 (440)	5.5 (140)	4.4 (111)	5/8 (M16)	60 (27)
<b>HD 2.0 x 16</b>	16 (400)	331,000 (37 400)	12,665,000 (1 431 099)	25,000 (110 000)	100 (440)	5.5 (140)	4.4 (111)	5/8 (M16)	64 (29)
<b>HD 2.0 x 18</b>	18 (450)	372,000 (42 000)	13,752,000 (1 553 971)	25,000 (110 000)	100 (440)	5.5 (140)	4.4 (111)	5/8 (M16)	68 (31)
<b>HD 2.0 x 20</b>	20 (500)	414,000 (46 800)	14,818,000 (1 674 434)	25,000 (110 000)	100 (440)	5.5 (140)	4.4 (111)	5/8 (M16)	73 (33)
<b>HD 2.0 x 24</b>	24 (600)	496,000 (56 100)	16,993,000 (1 920 178)	25,000 (110 000)	100 (440)	5.5 (140)	4.4 (111)	5/8 (M16)	79 (36)
<b>HD 2.0 x 28</b>	28 (700)	580,000 (65 500)	19,168,000 (2 165 922)	25,000 (110 000)	100 (440)	5.5 (140)	4.4 (111)	5/8 (M16)	93 (42)
<b>HD 2.0 x 32</b>	32 (800)	662,000 (74 800)	23,005,000 (2 599 589)	25,000 (110 000)	125 (560)	5.5 (140)	4.4 (111)	5/8 (M16)	108 (49)
<b>HD 2.0 x 36</b>	36 (900)	677,000 (76 500)	25,137,000 (2 840 514)	22,500 (100 000)	125 (560)	5.5 (140)	4.4 (111)	5/8 (M16)	117 (53)
<b>HD 2.0 x 40</b>	40 (1 000)	647,000 (73 100)	27,270,000 (3 081 440)	19,000 (86 000)	125 (560)	5.5 (140)	4.4 (111)	5/8 (M16)	124 (56)
<b>HD 2.0 x 48</b>	48 (1 200)	542,000 (61 200)	31,534,000 (3 563 292)	13,500 (60 000)	125 (560)	5.5 (140)	4.4 (111)	5/8 (M16)	141 (64)
<b>HD 2.0 x 56</b>	56 (1 400)	367,000 (41 650)	22,000,000 (2 500 000)	7,900 (35 000)	125 (560)	5.5 (140)	4.4 (111)	5/8 (M16)	161 (73)

# Heavy Duty Series Shock Absorber

## HD/HDA Series

### Technical Data

HD 2.0 x 10 → HD 2.0 x 56 Series

Heavy Duty Series

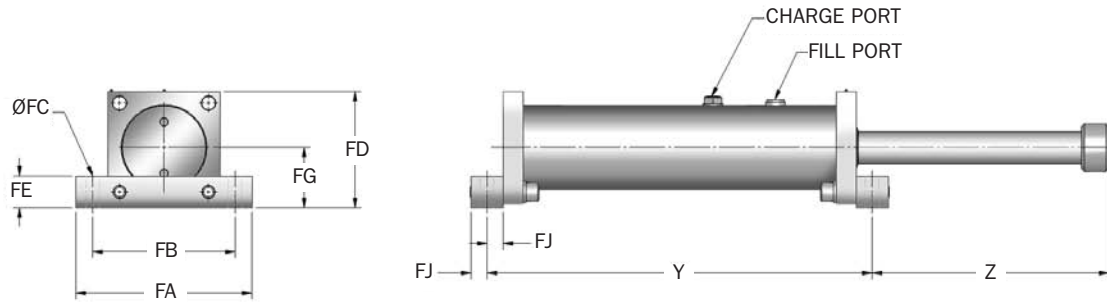

Note: For TF, FF and FR mounting, delete front foot and dimensions.

Catalog No./ Model	Foot Mount Dimensions														Charge Port Dimensions		
	A in. (mm)	B in. (mm)	D in. (mm)	E in. (mm)	F in. (mm)	H in. (mm)	Y in. (mm)	Z in. (mm)	FA in. (mm)	FB in. (mm)	FC in. (mm)	FD in. (mm)	FE in. (mm)	FG in. (mm)	FJ in. (mm)	CA in. (mm)	CB in. (mm)
HD 2.0 x 10	29.8 (757)	4.3 (110)	1.6 (40)	2.4 (60)	17.4 (441)	1.0 (25)	19.0 (481)	11.6 (296)	8.7 (220)	7.0 (178)	.67 (17)	5.8 (146)	1.6 (40)	3.0 (76)	.80 (20)	7.0 (179)	2.6 (65)
HD 2.0 x 12	33.8 (859)	4.3 (110)	1.6 (40)	2.4 (60)	19.4 (492)	1.0 (25)	21.0 (532)	13.6 (347)	8.7 (220)	7.0 (178)	.67 (17)	5.8 (146)	1.6 (40)	3.0 (76)	.80 (20)	7.0 (179)	2.6 (65)
HD 2.0 x 14	37.8 (960)	4.3 (110)	1.6 (40)	2.4 (60)	21.4 (543)	1.0 (25)	23.0 (583)	15.6 (397)	8.7 (220)	7.0 (178)	.67 (17)	5.8 (146)	1.6 (40)	3.0 (76)	.80 (20)	7.0 (179)	2.6 (65)
HD 2.0 x 16	41.8 (1 062)	4.3 (110)	1.6 (40)	2.4 (60)	23.4 (594)	1.0 (25)	25.0 (634)	17.6 (448)	8.7 (220)	7.0 (178)	.67 (17)	5.8 (146)	1.6 (40)	3.0 (76)	.80 (20)	7.0 (179)	2.6 (65)
HD 2.0 x 18	45.8 (1 164)	4.3 (110)	1.6 (40)	2.4 (60)	25.4 (645)	1.0 (25)	27.0 (685)	19.6 (499)	8.7 (220)	7.0 (178)	.67 (17)	5.8 (146)	1.6 (40)	3.0 (76)	.80 (20)	7.0 (179)	2.6 (65)
HD 2.0 x 20	49.8 (1 265)	4.3 (110)	1.6 (40)	2.4 (60)	27.4 (695)	1.0 (25)	29.0 (735)	21.6 (550)	8.7 (220)	7.0 (178)	.67 (17)	5.8 (146)	1.6 (40)	3.0 (76)	.80 (20)	7.0 (179)	2.6 (65)
HD 2.0 x 24	57.8 (1 469)	4.3 (110)	1.6 (40)	2.4 (60)	31.4 (797)	1.0 (25)	33.0 (837)	25.6 (652)	8.7 (220)	7.0 (178)	.67 (17)	5.8 (146)	1.6 (40)	3.0 (76)	.80 (20)	7.0 (179)	2.6 (65)
HD 2.0 x 28	65.8 (1 672)	4.3 (110)	1.6 (40)	2.4 (60)	35.4 (899)	1.0 (25)	37.0 (939)	29.6 (753)	8.7 (220)	7.0 (178)	.67 (17)	5.8 (146)	1.6 (40)	3.0 (76)	.80 (20)	7.0 (179)	2.6 (65)
HD 2.0 x 32	76.9 (1 953)	4.3 (110)	1.6 (40)	2.4 (60)	42.5 (1 079)	1.0 (25)	44.0 (1 119)	33.7 (854)	8.7 (220)	7.0 (178)	.67 (17)	5.8 (146)	1.6 (40)	3.0 (76)	.80 (20)	10.2 (260)	2.6 (65)
HD 2.0 x 36	84.7 (2 151)	4.3 (110)	1.6 (40)	2.4 (60)	46.4 (1 179)	1.0 (25)	48.0 (1 219)	37.5 (952)	8.7 (220)	7.0 (178)	.67 (17)	5.8 (146)	1.6 (40)	3.0 (76)	.80 (20)	10.2 (260)	2.6 (65)
HD 2.0 x 40	92.6 (2 351)	4.3 (110)	1.6 (40)	2.4 (60)	50.4 (1 279)	1.0 (25)	52.0 (1 319)	41.4 (1 052)	8.7 (220)	7.0 (178)	.67 (17)	5.8 (146)	1.6 (40)	3.0 (76)	.80 (20)	10.2 (260)	2.6 (65)
HD 2.0 x 48	108.3 (2 751)	4.3 (110)	1.6 (40)	2.4 (60)	58.0 (1 472)	1.0 (25)	59.5 (1 512)	49.6 (1 259)	8.7 (220)	7.0 (178)	.67 (17)	5.8 (146)	1.6 (40)	3.0 (76)	.80 (20)	10.2 (260)	2.6 (65)
HD 2.0 x 56	124.8 (3 171)	4.3 (110)	1.6 (40)	2.4 (60)	66.5 (1 689)	1.0 (25)	68.1 (1 729)	57.5 (1 462)	8.7 (220)	7.0 (178)	.67 (17)	5.8 (146)	1.6 (40)	3.0 (76)	.80 (20)	10.2 (260)	2.6 (65)

- Notes: 1. HD shock absorbers will function satisfactorily at 5% of their maximum rated energy per cycle. If less than these values, a smaller model should be specified.
2. It is recommended that the customer consult Enidine for safety-related overhead crane applications.
3. The energy data listed is for ideal linear impacts only. If side load conditions exist in the application, contact Enidine for sizing assistance.
4. Rear flange mounting of 12 inch strokes and longer not recommended. Front and rear flange or foot mount configurations are recommended.
5. Maximum cycle rate is 60 cycles/hr.
6. For impact velocities over 180 in./sec. (4.5 m/s), consult factory.

HD(A) 3.0 x 2 → HD 3.0 x 56 Series

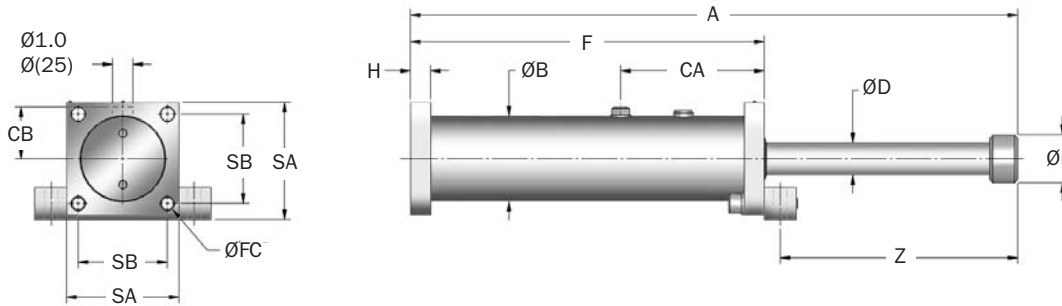

Note: For TF, FF and FR mounting, delete front foot and dimensions.

Catalog No./ Model	(S) Stroke in. (mm)	HD		HDA		(F <sub>p</sub> ) Max. Shock Force lbs. (N)	Nominal Return Force lbs. (N)	Flange Dimensions			Model Weight lbs. (Kg)
		(E <sub>T</sub> ) Max. in.-lbs./cycle (Nm/cycle)	(E <sub>T-C</sub> ) Max. in.-lbs./hour (Nm/hr)	(E <sub>T</sub> ) Max. in.-lbs./cycle (Nm/cycle)	(E <sub>T-C</sub> ) Max. in.-lbs./hour (Nm/hr)			SA in. (mm)	SB in. (mm)	Rec. Bolt Size in. (mm)	
HD(A) 3.0 x 2	2 (50)	83,000 (9 350)	4,965,000 (561 000)	40,000 (4 500)	2,400,000 (270 000)	50,000 (220 000)	125 (550)	6.7 (170)	4.9 (125)	3/4 (M20)	40 (21)
HD(A) 3.0 x 3	3 (75)	124,000 (14 000)	5,924,000 (669 412)	60,000 (6 800)	3,600,000 (408 000)	50,000 (220 000)	125 (550)	6.7 (170)	4.9 (125)	3/4 (M20)	42 (22)
HD(A) 3.0 x 5	5 (125)	207,000 (23 400)	7,210,000 (814 689)	100,000 (11 300)	6,000,000 (678 000)	50,000 (220 000)	125 (550)	6.7 (170)	4.9 (125)	3/4 (M20)	48 (25)
HD(A) 3.0 x 8	8 (200)	331,000 (37 400)	9,100,000 (1 028 331)	160,000 (18 100)	9,400,000 (1 056 816)	50,000 (220 000)	125 (550)	6.7 (170)	4.9 (125)	3/4 (M20)	57 (29)
HD 3.0 x 10	10 (250)	414,000 (46 800)	10,386,000 (1 173 607)	— —	— —	50,000 (220 000)	125 (550)	6.7 (170)	4.9 (125)	3/4 (M20)	64 (32)
HD(A) 3.0 x 12	12 (300)	497,000 (56 100)	11,672,000 (1 318 884)	240,000 (27 200)	12,000,000 (1 347 370)	50,000 (220 000)	125 (550)	6.7 (170)	4.9 (125)	3/4 (M20)	71 (35)
HD 3.0 x 14	14 (350)	580,000 (65 500)	14,218,000 (1 606 589)	— —	— —	50,000 (220 000)	125 (550)	6.7 (170)	4.9 (125)	3/4 (M20)	88 (43)
HD 3.0 x 16	16 (400)	662,000 (74 800)	15,478,000 (1 749 017)	— —	— —	50,000 (220 000)	125 (550)	6.7 (170)	4.9 (125)	3/4 (M20)	93 (45)
HD 3.0 x 18	18 (450)	745,000 (84 200)	16,789,000 (1 897 142)	— —	— —	50,000 (220 000)	125 (550)	6.7 (170)	4.9 (125)	3/4 (M20)	99 (48)
HD 3.0 x 20	20 (500)	828,000 (93 500)	18,075,000 (2 042 419)	— —	— —	50,000 (220 000)	125 (550)	6.7 (170)	4.9 (125)	3/4 (M20)	106 (51)
HD 3.0 x 24	24 (600)	993,000 (112 200)	20,621,000 (2 330 124)	— —	— —	50,000 (220 000)	125 (550)	6.7 (170)	4.9 (125)	3/4 (M20)	119 (57)
HD 3.0 x 28	28 (700)	1,159,000 (130 900)	23,192,000 (2 620 677)	— —	— —	50,000 (220 000)	125 (550)	6.7 (170)	4.9 (125)	3/4 (M20)	130 (62)
HD 3.0 x 32	32 (800)	1,083,000 (122 400)	25,738,000 (2 908 382)	— —	— —	40,500 (180 000)	160 (710)	6.7 (170)	4.9 (125)	3/4 (M20)	143 (68)
HD 3.0 x 36	36 (900)	1,083,000 (122 400)	29,343,000 (3 315 726)	— —	— —	36,000 (160 000)	160 (710)	6.7 (170)	4.9 (125)	3/4 (M20)	163 (77)
HD 3.0 x 40	40 (1 000)	1,053,000 (119 000)	31,864,000 (3 600 582)	— —	— —	31,500 (140 000)	160 (710)	6.7 (170)	4.9 (125)	3/4 (M20)	176 (85)
HD 3.0 x 48	48 (1 200)	867,000 (97 900)	36,905,000 (4 170 294)	— —	— —	21,500 (96 000)	160 (710)	6.7 (170)	4.9 (125)	3/4 (M20)	200 (94)
HD 3.0 x 56	56 (1 422)	576,000 (65 450)	34,320,000 (3 900 000)	— —	— —	12,500 (55 000)	160 (710)	6.7 (170)	4.9 (125)	3/4 (M20)	235 (106)

# Heavy Duty Series Shock Absorber

## HD/HDA Series

### Technical Data

HD 3.0 x 2 → HD 3.0 x 56 Series

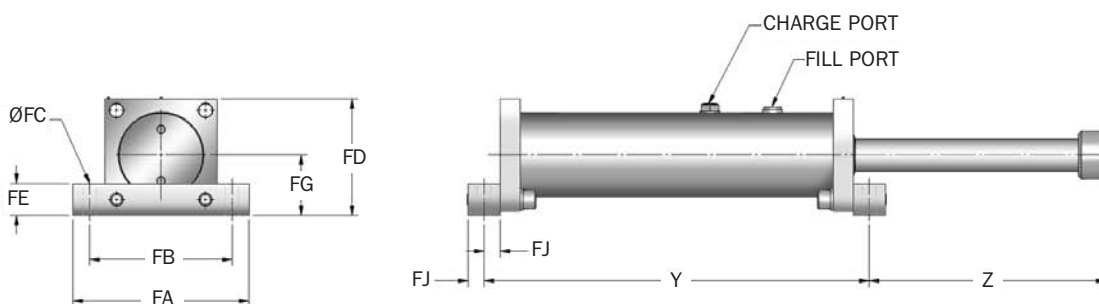

Note: For TF, FF and FR mounting, delete front foot and dimensions.

Catalog No./ Model	Foot Mount Dimensions																	Charge Port Dimensions		
	A in. (mm)	B in. (mm)	D in. (mm)	E in. (mm)	HD F in. (mm)	HDA F in. (mm)	H in. (mm)	HD Y in. (mm)	HDA Y in. (mm)	HD Z in. (mm)	HDA Z in. (mm)	FA in. (mm)	FB in. (mm)	FC in. (mm)	FD in. (mm)	FE in. (mm)	FG in. (mm)	FJ in. (mm)	CA in. (mm)	CB in. (mm)
HD(A) 3.0 x 2	13.2 (336)	5.1 (130)	1.8 (45)	2.8 (70)	8.0 (203)	8.4 (213)	1.0 (25)	10.0 (253)	10.4 (263)	4.2 (108)	3.8 (98)	10.0 (255)	8.5 (216)	.87 (22)	6.8 (173)	2.0 (50)	3.5 (88)	1.0 (25)	5.3 (134)	3.0 (75)
HD(A) 3.0 x 3	15.2 (387)	5.1 (130)	1.8 (45)	2.8 (70)	9.0 (229)	9.4 (239)	1.0 (25)	11.0 (279)	11.4 (289)	5.2 (133)	4.8 (123)	10.0 (255)	8.5 (216)	.87 (22)	6.8 (173)	2.0 (50)	3.5 (88)	1.0 (25)	5.3 (134)	3.0 (75)
HD(A) 3.0 x 5	19.2 (489)	5.1 (130)	1.8 (45)	2.8 (70)	11.0 (280)	11.4 (9290)	1.0 (25)	13.0 (330)	13.4 (340)	7.2 (184)	6.8 (174)	10.0 (255)	8.5 (216)	.87 (22)	6.8 (173)	2.0 (50)	3.5 (88)	1.0 (25)	5.3 (134)	3.0 (75)
HD(A) 3.0 x 8	25.2 (640)	5.1 (130)	1.8 (45)	2.8 (70)	14.0 (355)	14.4 (365)	1.0 (25)	16.0 (405)	16.4 (415)	10.2 (260)	9.8 (250)	10.0 (255)	8.5 (216)	.87 (22)	6.8 (173)	2.0 (50)	3.5 (88)	1.0 (25)	5.3 (134)	3.0 (75)
HD 3.0 x 10	29.2 (742)	5.1 (130)	1.8 (45)	2.8 (70)	16.0 (406)	N/A	1.0 (25)	18.0 (456)	N/A	12.2 (311)	N/A	10.0 (255)	8.5 (216)	.87 (22)	6.8 (173)	2.0 (50)	3.5 (88)	1.0 (25)	5.3 (134)	3.0 (75)
HD(A) 3.0 x 12	33.2 (844)	5.1 (130)	1.8 (45)	2.8 (70)	18.0 (457)	18.4 (467)	1.0 (25)	20.0 (507)	20.4 (517)	14.2 (362)	13.8 (352)	10.0 (255)	8.5 (216)	.87 (22)	6.8 (173)	2.0 (50)	3.5 (88)	1.0 (25)	5.3 (134)	3.0 (75)
HD 3.0 x 14	39.2 (995)	5.1 (130)	1.8 (45)	2.8 (70)	22.0 (558)	-	1.0 (25)	24.0 (608)	-	16.2 (412)	-	10.0 (255)	8.5 (216)	.87 (22)	6.8 (173)	2.0 (50)	3.5 (88)	1.0 (25)	7.2 (184)	3.0 (75)
HD 3.0 x 16	43.2 (1 097)	5.1 (130)	1.8 (45)	2.8 (70)	24.0 (609)	-	1.0 (25)	26.0 (659)	-	18.2 (463)	-	10.0 (255)	8.5 (216)	.87 (22)	6.8 (173)	2.0 (50)	3.5 (88)	1.0 (25)	7.2 (184)	3.0 (75)
HD 3.0 x 18	47.2 (1 199)	5.1 (130)	1.8 (45)	2.8 (70)	26.0 (660)	-	1.0 (25)	28.0 (710)	-	20.2 (514)	-	10.0 (255)	8.5 (216)	.87 (22)	6.8 (173)	2.0 (50)	3.5 (88)	1.0 (25)	7.2 (184)	3.0 (75)
HD 3.0 x 20	51.2 (1 301)	5.1 (130)	1.8 (45)	2.8 (70)	28.0 (711)	-	1.0 (25)	30.0 (761)	-	22.2 (565)	-	10.0 (255)	8.5 (216)	.87 (22)	6.8 (173)	2.0 (50)	3.5 (88)	1.0 (25)	7.2 (184)	3.0 (75)
HD 3.0 x 24	59.2 (1 504)	5.1 (130)	1.8 (45)	2.8 (70)	32.0 (812)	-	1.0 (25)	34.0 (862)	-	26.2 (667)	-	10.0 (255)	8.5 (216)	.87 (22)	6.8 (173)	2.0 (50)	3.5 (88)	1.0 (25)	7.2 (184)	3.0 (75)
HD 3.0 x 28	67.2 (1 707)	5.1 (130)	1.8 (45)	2.8 (70)	36.0 (914)	-	1.0 (25)	38.0 (964)	-	30.2 (768)	-	10.0 (255)	8.5 (216)	.87 (22)	6.8 (173)	2.0 (50)	3.5 (88)	1.0 (25)	7.2 (184)	3.0 (75)
HD 3.0 x 32	75.2 (1 910)	5.1 (130)	1.8 (45)	2.8 (70)	40.0 (1 015)	-	1.0 (25)	42.0 (1 065)	-	34.2 (870)	-	10.0 (255)	8.5 (216)	.87 (22)	6.8 (173)	2.0 (50)	3.5 (88)	1.0 (25)	7.2 (184)	3.0 (75)
HD 3.0 x 36	84.9 (2 156)	5.1 (130)	1.8 (45)	2.8 (70)	45.8 (1 164)	-	1.0 (25)	47.8 (1 214)	-	38.1 (967)	-	10.0 (255)	8.5 (216)	.87 (22)	6.8 (173)	2.0 (50)	3.5 (88)	1.0 (25)	9.2 (234)	3.0 (75)
HD 3.0 x 40	92.8 (2 356)	5.1 (130)	1.8 (45)	2.8 (70)	49.8 (1 264)	-	1.0 (25)	51.7 (1 314)	-	42.1 (1 067)	-	10.0 (255)	8.5 (216)	.87 (22)	6.8 (173)	2.0 (50)	3.5 (88)	1.0 (25)	9.2 (234)	3.0 (75)
HD 3.0 x 48	108.5 (2 756)	5.1 (130)	1.8 (45)	2.8 (70)	57.6 (1 464)	-	1.0 (25)	59.6 (1 514)	-	49.9 (1 267)	-	10.0 (255)	8.5 (216)	.87 (22)	6.8 (173)	2.0 (50)	3.5 (88)	1.0 (25)	9.2 (234)	3.0 (75)
HD 3.0 x 56	124.2 (3 156)	5.1 (130)	1.8 (45)	2.8 (70)	65.5 (1 664)	-	1.0 (25)	67.5 (1 714)	-	57.7 (1 467)	-	10.0 (255)	8.5 (216)	.87 (22)	6.8 (173)	2.0 (50)	3.5 (88)	1.0 (25)	9.2 (234)	3.0 (75)

- Notes: 1. HD shock absorbers will function satisfactorily at 5% of their maximum rated energy per cycle.  
 HDA models will function satisfactorily at 10% of their maximum rated energy per cycle. If less than these values, a smaller model should be specified.  
 2. It is recommended that the customer consult Enidine for safety-related overhead crane applications.  
 3. The energy data listed is for ideal linear impacts only. If side load conditions exist in the application, contact Enidine for sizing assistance.  
 4. Rear flange mounting of 12 inch strokes and longer not recommended. Front and rear flange or foot mount configurations are recommended.  
 5. HDA models which have an impact velocity below 30 in./sec., please contact Enidine for sizing assistance.  
 6. Maximum cycle rate is 60 cycles/hr.  
 7. For impact velocities over 180 in./sec. (4.5 m/s), consult factory.

HD 3.5 x 2 → HD 3.5 x 48 Series

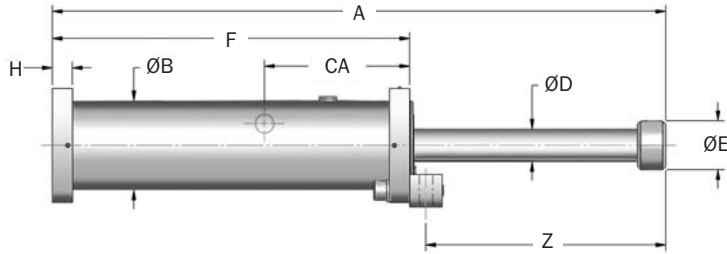
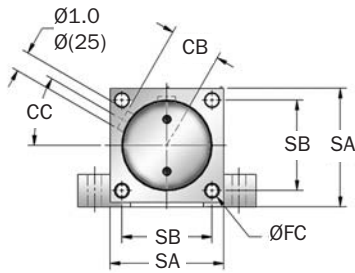

Note: For TF, FF and FR mounting, delete front foot and dimensions.

Catalog No./ Model	(S) Stroke in. (mm)	(E <sub>T</sub> ) Max. in.-lbs./cycle (Nm/cycle)	(E <sub>T</sub> C) Max. in.-lbs./hour (Nm/hr)	(F <sub>P</sub> ) Max. Shock Force lbs. (N)	Nominal Return Force lbs. (N)	Flange Dimensions			Model Weight (lbs.) (Kg)
						SA in. (mm)	SB in. (mm)	Rec. Bolt Size in. (mm)	
<b>HD 3.5 x 2</b>	2 (50)	112,500 (12 750)	7,345,500 (830 000)	67,500 (300 000)	195 (860)	7.9 (200)	6.3 (160)	<sup>3</sup> / <sub>4</sub> (M20)	73 (33)
<b>HD 3.5 x 4</b>	4 (100)	225,500 (25 500)	8,850,000 (1 000 000)	67,500 (300 000)	195 (860)	7.9 (200)	6.3 (160)	<sup>3</sup> / <sub>4</sub> (M20)	82 (37)
<b>HD 3.5 x 6</b>	6 (150)	338,500 (38 250)	10,620,000 (1 200 000)	67,500 (300 000)	195 (860)	7.9 (200)	6.3 (160)	<sup>3</sup> / <sub>4</sub> (M20)	90 (41)
<b>HD 3.5 x 8</b>	8 (200)	451,500 (51 000)	11,947,500 (1 350 000)	67,500 (300 000)	195 (860)	7.9 (200)	6.3 (160)	<sup>3</sup> / <sub>4</sub> (M20)	99 (45)
<b>HD 3.5 x 10</b>	10 (250)	564,000 (63 750)	13,717,500 (1 550 000)	67,500 (300 000)	195 (860)	7.9 (200)	6.3 (160)	<sup>3</sup> / <sub>4</sub> (M20)	108 (49)
<b>HD 3.5 x 12</b>	12 (300)	677,000 (76 500)	15,045,000 (1 700 000)	67,500 (300 000)	195 (860)	7.9 (200)	6.3 (160)	<sup>3</sup> / <sub>4</sub> (M20)	117 (53)
<b>HD 3.5 x 16</b>	16 (400)	903,000 (102 000)	18,142,500 (2 050 000)	67,500 (300 000)	195 (860)	7.9 (200)	6.3 (160)	<sup>3</sup> / <sub>4</sub> (M20)	132 (60)
<b>HD 3.5 x 20</b>	20 (500)	1,128,500 (127 500)	23,010,000 (2 600 000)	67,500 (300 000)	195 (860)	7.9 (200)	6.3 (160)	<sup>3</sup> / <sub>4</sub> (M20)	163 (74)
<b>HD 3.5 x 24</b>	24 (600)	1,354,000 (153 000)	25,665,000 (2 900 000)	67,500 (300 000)	195 (860)	7.9 (200)	6.3 (160)	<sup>3</sup> / <sub>4</sub> (M20)	179 (81)
<b>HD 3.5 x 28</b>	28 (700)	1,580,000 (178 500)	28,762,500 (3 250 000)	67,500 (300 000)	195 (860)	7.9 (200)	6.3 (160)	<sup>3</sup> / <sub>4</sub> (M20)	196 (89)
<b>HD 3.5 x 32</b>	32 (800)	1,805,500 (204 000)	31,860,000 (3 600 000)	67,500 (300 000)	195 (860)	7.9 (200)	6.3 (160)	<sup>3</sup> / <sub>4</sub> (M20)	214 (97)
<b>HD 3.5 x 36</b>	36 (900)	1,760,000 (198 900)	34,957,500 (3 950 000)	58,500 (260 000)	195 (860)	7.9 (200)	6.3 (160)	<sup>3</sup> / <sub>4</sub> (M20)	231 (105)
<b>HD 3.5 x 40</b>	40 (1 000)	1,617,500 (182 750)	38,055,000 (4 300 000)	48,500 (215 000)	195 (860)	7.9 (200)	6.3 (160)	<sup>3</sup> / <sub>4</sub> (M20)	247 (112)
<b>HD 3.5 x 48</b>	48 (1 200)	1,400,000 (158 100)	44,250,000 (5 000 000)	35,000 (155 000)	195 (860)	7.9 (200)	6.3 (160)	<sup>3</sup> / <sub>4</sub> (M20)	282 (128)

# Heavy Duty Series Shock Absorber

## HD/HDA Series

### Technical Data

HD 3.5 x 10 → HD 3.5 x 48 Series

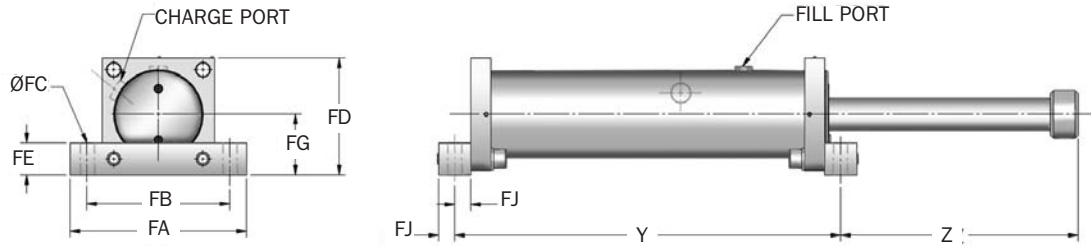

Note: For TF, FF and FR mounting, delete front foot and dimensions.

Catalog No./Model	Foot Mount Dimensions															Charge Port Dimensions		
	A in. (mm)	B in. (mm)	D in. (mm)	E in. (mm)	F in. (mm)	H in. (mm)	Y in. (mm)	Z in. (mm)	FA in. (mm)	FB in. (mm)	FC in. (mm)	FD in. (mm)	FE in. (mm)	FG in. (mm)	FJ in. (mm)	CA in. (mm)	CB in. (mm)	CC deg.
HD 3.5 x 2	13.9 (658)	6.1 (155)	2.2 (56)	3.2 (82)	9.6 (396)	1.0 (25)	11.6 (446)	3.3 (237)	11.8 (300)	9.8 (250)	1.06 (27)	8.3 (210)	2.0 (50)	4.3 (110)	1.0 (25)	5.5 (139)	3.4 (86)	90° (90°)
HD 3.5 x 4	18.0 (760)	6.1 (155)	2.2 (56)	3.2 (82)	11.6 (447)	1.0 (25)	13.6 (497)	5.4 (288)	11.8 (300)	9.8 (250)	1.06 (27)	8.3 (210)	2.0 (50)	4.3 (110)	1.0 (25)	5.5 (139)	3.4 (86)	90° (90°)
HD 3.5 x 6	21.9 (862)	6.1 (155)	2.2 (56)	3.2 (82)	13.6 (498)	1.0 (25)	15.6 (548)	7.3 (339)	11.8 (300)	9.8 (250)	1.06 (27)	8.3 (210)	2.0 (50)	4.3 (110)	1.0 (25)	5.5 (139)	3.4 (86)	90° (90°)
HD 3.5 x 8	25.9 (1064)	6.1 (155)	2.2 (56)	3.2 (82)	15.6 (599)	1.0 (25)	17.6 (649)	9.3 (440)	11.8 (300)	9.8 (250)	1.06 (27)	8.3 (210)	2.0 (50)	4.3 (110)	1.0 (25)	5.5 (139)	3.4 (86)	90° (90°)
HD 3.5 x 10	29.9 (354)	6.1 (155)	2.2 (56)	3.2 (82)	17.6 (244)	1.0 (25)	19.6 (294)	11.3 (85)	11.8 (300)	9.8 (250)	1.06 (27)	8.3 (210)	2.0 (50)	4.3 (110)	1.0 (25)	5.5 (139)	3.4 (86)	90° (90°)
HD 3.5 x 12	33.9 (456)	6.1 (155)	2.2 (56)	3.2 (82)	19.6 (295)	1.0 (25)	21.6 (345)	13.3 (136)	11.8 (300)	9.8 (250)	1.06 (27)	8.3 (210)	2.0 (50)	4.3 (110)	1.0 (25)	5.5 (139)	3.4 (86)	90° (90°)
HD 3.5 x 16	41.9 (556)	6.1 (155)	2.2 (56)	3.2 (82)	23.6 (345)	1.0 (25)	25.6 (395)	17.3 (186)	11.8 (300)	9.8 (250)	1.06 (27)	8.3 (210)	2.0 (50)	4.3 (110)	1.0 (25)	5.5 (139)	3.4 (86)	90° (90°)
HD 3.5 x 20	52.0 (1323)	6.1 (155)	2.2 (56)	3.2 (82)	29.8 (756)	1.0 (25)	31.8 (806)	21.2 (542)	11.8 (300)	9.8 (250)	1.06 (27)	8.3 (210)	2.0 (50)	4.3 (110)	1.0 (25)	7.6 (194)	3.4 (86)	90° (90°)
HD 3.5 x 24	60.1 (1527)	6.1 (155)	2.2 (56)	3.2 (82)	33.8 (858)	1.0 (25)	35.8 (908)	25.3 (644)	11.8 (300)	9.8 (250)	1.06 (27)	8.3 (210)	2.0 (50)	4.3 (110)	1.0 (25)	7.6 (194)	3.4 (86)	90° (90°)
HD 3.5 x 28	68.0 (1729)	6.1 (155)	2.2 (56)	3.2 (82)	37.8 (959)	1.0 (25)	39.8 (1009)	29.2 (745)	11.8 (300)	9.8 (250)	1.06 (27)	8.3 (210)	2.0 (50)	4.3 (110)	1.0 (25)	7.6 (194)	3.4 (86)	90° (90°)
HD 3.5 x 32	76.1 (1933)	6.1 (155)	2.2 (56)	3.2 (82)	41.8 (1061)	1.0 (25)	43.8 (1111)	33.2 (847)	11.8 (300)	9.8 (250)	1.06 (27)	8.3 (210)	2.0 (50)	4.3 (110)	1.0 (25)	7.6 (194)	3.4 (86)	90° (90°)
HD 3.5 x 36	84.1 (2137)	6.1 (155)	2.2 (56)	3.2 (82)	45.8 (1163)	1.0 (25)	47.8 (1213)	37.3 (949)	11.8 (300)	9.8 (250)	1.06 (27)	8.3 (210)	2.0 (50)	4.3 (110)	1.0 (25)	7.6 (194)	3.4 (86)	90° (90°)
HD 3.5 x 40	92.1 (2339)	6.1 (155)	2.2 (56)	3.2 (82)	49.8 (1264)	1.0 (25)	51.8 (1314)	41.3 (1050)	11.8 (300)	9.8 (250)	1.06 (27)	8.3 (210)	2.0 (50)	4.3 (110)	1.0 (25)	7.6 (194)	3.4 (86)	90° (90°)
HD 3.5 x 48	107.8 (2739)	6.1 (155)	2.2 (56)	3.2 (82)	57.6 (1464)	1.0 (25)	59.6 (1514)	49.2 (1250)	11.8 (300)	9.8 (250)	1.06 (27)	8.3 (210)	2.0 (50)	4.3 (110)	1.0 (25)	7.6 (194)	3.4 (86)	90° (90°)

- Notes:
1. HD shock absorbers will function satisfactorily at 5% of their maximum rated energy per cycle.
  2. It is recommended that the customer consult Enidine for safety-related overhead crane applications.
  3. The energy data listed is for ideal linear impacts only. If side load conditions exist in the application, contact Enidine for sizing assistance.
  4. Rear flange mounting of 12 inch strokes and longer not recommended. Front and rear flange or foot mount configurations are recommended.
  5. Maximum cycle rate is 60 cycles/hr.
  6. For impact velocities over 180 in./sec. (4.5 m/s), consult factory.

HD(A) 4.0 x 2 → HD 4.0 x 48 Series

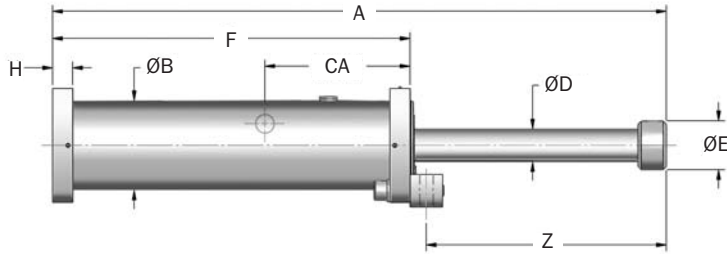
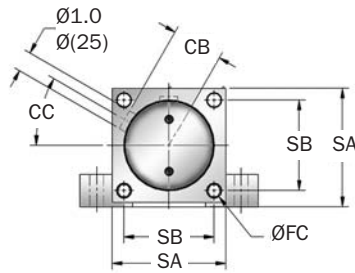

Note: For TF, FF and FR mounting, delete front foot and dimensions.

Catalog No./ Model	(S) Stroke in. (mm)	HD		HDA		(F <sub>p</sub> ) Max. Shock Force lbs. (N)	Nominal Return Force lbs. (N)	Flange Dimensions			Model Weight lbs. (Kg)
		(E <sub>T</sub> ) Max. in.-lbs./cycle (Nm/cycle)	(E <sub>T-C</sub> ) Max. in.-lbs./hour (Nm/hr)	(E <sub>T</sub> ) Max. in.-lbs./cycle (Nm/cycle)	(E <sub>T-C</sub> ) Max. in.-lbs./hour (Nm/hr)			SA in. (mm)	SB in. (mm)	Rec. Bolt Size in. (mm)	
HD(A) 4.0 x 2	2 (50)	134,000 (15 100)	8,018,000 (906 000)	120,000 (13 500)	7,200,000 (810 000)	80,000 (355 000)	245 (1 090)	9.8 (250)	7.8 (197)	1 (M24)	141 (64)
HD(A) 4.0 x 4	4 (100)	268,000 (30 200)	13,302,000 (1 503 152)	240,000 (27 000)	13,700,000 (1 546 721)	80,000 (355 000)	245 (1 090)	9.8 (250)	7.8 (197)	1 (M24)	154 (70)
HD(A) 4.0 x 6	6 (150)	400,000 (45 300)	15,230,000 (1 721 000)	360,000 (40 500)	15,600,000 (1 764 569)	80,000 (355 000)	245 (1 090)	9.8 (250)	7.8 (197)	1 (M24)	168 (76)
HD(A) 4.0 x 8	8 (200)	535,000 (60 400)	17,235,000 (1 947 562)	480,000 (54 000)	17,600,000 (1 991 131)	80,000 (355 000)	245 (1 090)	9.8 (250)	7.8 (197)	1 (M24)	181 (82)
HD(A) 4.0 x 10	10 (250)	668,000 (75 400)	19,163,000 (2 165 410)	600,000 (67 500)	19,600,000 (2 208 980)	80,000 (355 000)	245 (1 090)	9.8 (250)	7.8 (197)	1 (M24)	192 (87)
HD 4.0 x 12	12 (300)	800,000 (90 500)	24,754,000 (2 797 169)	—	—	80,000 (355 000)	245 (1 090)	9.8 (250)	7.8 (197)	1 (M24)	238 (108)
HD 4.0 x 16	16 (400)	1,068,000 (120 700)	28,648,000 (3 237 222)	—	—	80,000 (355 000)	245 (1 090)	9.8 (250)	7.8 (197)	1 (M24)	265 (120)
HD 4.0 x 20	20 (500)	1,336,000 (150 900)	32,581,000 (3 681 633)	—	—	80,000 (355 000)	245 (1 090)	9.8 (250)	7.8 (197)	1 (M24)	290 (131)
HD 4.0 x 24	24 (600)	1,602,000 (181 000)	36,514,000 (4 126 043)	—	—	80,000 (355 000)	245 (1 090)	9.8 (250)	7.8 (197)	1 (M24)	317 (144)
HD 4.0 x 28	28 (700)	1,870,000 (211 200)	40,408,000 (4 566 096)	—	—	80,000 (355 000)	245 (1 090)	9.8 (250)	7.8 (197)	1 (M24)	346 (157)
HD 4.0 x 32	32 (800)	2,137,000 (241 400)	44,341,000 (5 010 506)	—	—	80,000 (355 000)	245 (1 090)	9.8 (250)	7.8 (197)	1 (M24)	375 (170)
HD 4.0 x 36	36 (900)	2,404,000 (271 600)	48,274,000 (5 454 916)	—	—	80,000 (355 000)	245 (1 090)	9.8 (250)	7.8 (197)	1 (M24)	403 (183)
HD 4.0 x 40	40 (1 000)	2,182,000 (246 500)	52,168,000 (5 894 969)	—	—	65,000 (290 000)	245 (1 090)	9.8 (250)	7.8 (197)	1 (M24)	430 (195)
HD 4.0 x 48	48 (1 200)	1,806,000 (204 000)	59,880,000 (6 766 361)	—	—	45,000 (200 000)	245 (1 090)	9.8 (250)	7.8 (197)	1 (M24)	485 (220)

# Heavy Duty Series Shock Absorber

## HD/HDA Series

### Technical Data

HD 4.0 x 2 → HD 4.0 x 48 Series

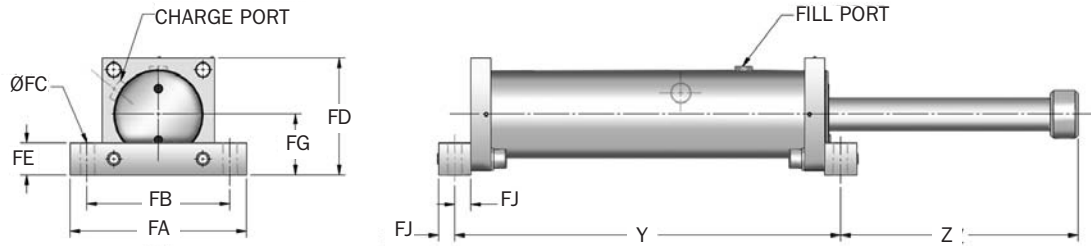

Note: For TE, FF and FR mounting, delete front foot and dimensions.

Catalog No./ Model	Foot Mount Dimensions																Charge Port Dimensions				
	A in. (mm)	B in. (mm)	D in. (mm)	E in. (mm)	HD F in. (mm)	HDA F in. (mm)	H in. (mm)	HD Y in. (mm)	HDA Y in. (mm)	HD Z in. (mm)	HDA Z in. (mm)	FA in. (mm)	FB in. (mm)	FC in. (mm)	FD in. (mm)	FE in. (mm)	FG in. (mm)	FJ in. (mm)	CA in. (mm)	CB in. (mm)	CC deg.
HD(A) 4.0 x 2	16.9 (430)	7.9 (200)	2.5 (63)	3.9 (100)	11.6 (294)	12.0 (304)	1.6 (40)	13.5 (344)	13.9 (354)	4.4 (111)	4.0 (101)	14.2 (360)	12.5 (317)	1.06 (27)	9.9 (252)	2.0 (50)	5.0 (127)	1.0 (25)	8.7 (220)	4.2 (107)	155° (155°)
HD(A) 4.0 x 4	20.9 (532)	7.9 (200)	2.5 (63)	3.9 (100)	13.6 (345)	14.0 (355)	1.6 (40)	15.5 (395)	15.9 (405)	6.4 (162)	6.0 (152)	14.2 (360)	12.5 (317)	1.06 (27)	9.9 (252)	2.0 (50)	5.0 (127)	1.0 (25)	8.7 (220)	4.2 (107)	155° (155°)
HD(A) 4.0 x 6	24.9 (632)	7.9 (200)	2.5 (63)	3.9 (100)	15.6 (395)	16.0 (405)	1.6 (40)	17.5 (445)	17.9 (455)	8.4 (212)	8.0 (202)	14.2 (360)	12.5 (317)	1.06 (27)	9.9 (252)	2.0 (50)	5.0 (127)	1.0 (25)	8.7 (220)	4.2 (107)	155° (155°)
HD(A) 4.0 x 8	28.9 (735)	7.9 (200)	2.5 (63)	3.9 (100)	17.6 (447)	18.0 (457)	1.6 (40)	19.5 (497)	19.9 (507)	10.4 (263)	10.0 (253)	14.2 (360)	12.5 (317)	1.06 (27)	9.9 (252)	2.0 (50)	5.0 (127)	1.0 (25)	8.7 (220)	4.2 (107)	155° (155°)
HD(A) 4.0 x 10	32.9 (836)	7.9 (200)	2.5 (63)	3.9 (100)	19.6 (497)	20.0 (507)	1.6 (40)	21.5 (547)	21.9 (557)	12.4 (314)	12.0 (304)	14.2 (360)	12.5 (317)	1.06 (27)	9.9 (252)	2.0 (50)	5.0 (127)	1.0 (25)	8.7 (220)	4.2 (107)	155° (155°)
HD 4.0 x 12	40.6 (1 032)	7.9 (200)	2.5 (63)	3.9 (100)	25.3 (642)	-	1.6 (40)	27.2 (692)	-	14.4 (365)	-	14.2 (360)	12.5 (317)	1.06 (27)	9.9 (252)	2.0 (50)	5.0 (127)	1.0 (25)	12.2 (310)	4.2 (107)	30° (30°)
HD 4.0 x 16	48.6 (1 234)	7.9 (200)	2.5 (63)	3.9 (100)	29.3 (743)	-	1.6 (40)	31.2 (793)	-	18.4 (466)	-	14.2 (360)	12.5 (317)	1.06 (27)	9.9 (252)	2.0 (50)	5.0 (127)	1.0 (25)	12.2 (310)	4.2 (107)	30° (30°)
HD 4.0 x 20	56.6 (1 438)	7.9 (200)	2.5 (63)	3.9 (100)	33.3 (845)	-	1.6 (40)	35.2 (895)	-	22.4 (568)	-	14.2 (360)	12.5 (317)	1.06 (27)	9.9 (252)	2.0 (50)	5.0 (127)	1.0 (25)	12.2 (310)	4.2 (107)	30° (30°)
HD 4.0 x 24	64.6 (1 642)	7.9 (200)	2.5 (63)	3.9 (100)	37.3 (947)	-	1.6 (40)	39.2 (997)	-	26.5 (670)	-	14.2 (360)	12.5 (317)	1.06 (27)	9.9 (252)	2.0 (50)	5.0 (127)	1.0 (25)	12.2 (310)	4.2 (107)	30° (30°)
HD 4.0 x 28	72.6 (1 844)	7.9 (200)	2.5 (63)	3.9 (100)	41.3 (1 048)	-	1.6 (40)	43.2 (1 098)	-	30.4 (771)	-	14.2 (360)	12.5 (317)	1.06 (27)	9.9 (252)	2.0 (50)	5.0 (127)	1.0 (25)	12.2 (310)	4.2 (107)	30° (30°)
HD 4.0 x 32	80.6 (2 048)	7.9 (200)	2.5 (63)	3.9 (100)	45.3 (1 150)	-	1.6 (40)	47.2 (1 200)	-	34.4 (873)	-	14.2 (360)	12.5 (317)	1.06 (27)	9.9 (252)	2.0 (50)	5.0 (127)	1.0 (25)	12.2 (310)	4.2 (107)	30° (30°)
HD 4.0 x 36	88.7 (2 252)	7.9 (200)	2.5 (63)	3.9 (100)	49.3 (1 252)	-	1.6 (40)	51.2 (1 302)	-	38.5 (975)	-	14.2 (360)	12.5 (317)	1.06 (27)	9.9 (252)	2.0 (50)	5.0 (127)	1.0 (25)	12.2 (310)	4.2 (107)	30° (30°)
HD 4.0 x 40	96.6 (2 454)	7.9 (200)	2.5 (63)	3.9 (100)	53.3 (1 353)	-	1.6 (40)	55.2 (1 403)	-	42.4 (1 076)	-	14.2 (360)	12.5 (317)	1.06 (27)	9.9 (252)	2.0 (50)	5.0 (127)	1.0 (25)	12.2 (310)	4.2 (107)	30° (30°)
HD 4.0 x 48	112.4 (2 854)	7.9 (200)	2.5 (63)	3.9 (100)	61.1 (1 553)	-	1.6 (40)	63.1 (1 603)	-	50.3 (1 276)	-	14.2 (360)	12.5 (317)	1.06 (27)	9.9 (252)	2.0 (50)	5.0 (127)	1.0 (25)	12.2 (310)	4.2 (107)	30° (30°)

- Notes: 1. HD shock absorbers will function satisfactorily at 5% of their maximum rated energy per cycle.  
 HDA models will function satisfactorily at 10% of their maximum rated energy per cycle. If less than these values, a smaller model should be specified.  
 2. It is recommended that the customer consult Enidine for safety-related overhead crane applications.  
 3. The energy data listed is for ideal linear impacts only. If side load conditions exist in the application, contact Enidine for sizing assistance.  
 4. Rear flange mounting of 12 inch strokes and longer not recommended. Front and rear flange or foot mount configurations are recommended.  
 5. HDA models which have an impact velocity below 30 in./sec., please contact Enidine for sizing assistance.  
 6. Maximum cycle rate is 60 cycles/hr.  
 7. For impact velocities over 180 in./sec. (4.5 m/s), consult factory.

HD(A) 5.0 x 4 → HD 5.0 x 48 Series

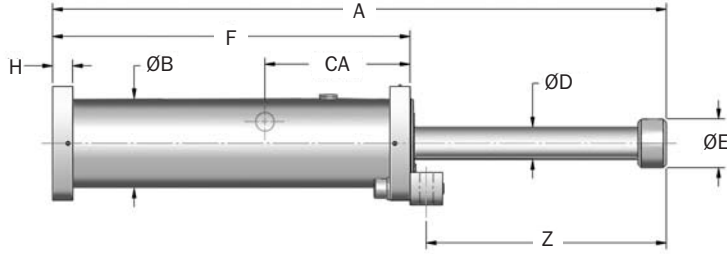
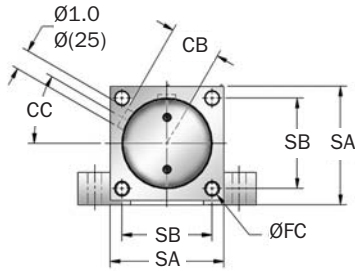

Note: For TF, FF and FR mounting, delete front foot and dimensions.

Catalog No./ Model	(S) Stroke in. (mm)	HD		HDA		(F <sub>p</sub> ) Max. Shock Force lbs. (N)	Nominal Return Force lbs. (N)	Flange Dimensions			Model Weight lbs. (Kg)
		(E <sub>T</sub> ) Max. in.-lbs./cycle (Nm/cycle)	(E <sub>T-C</sub> ) Max. in.-lbs./hour (Nm/hr)	(E <sub>T</sub> ) Max. in.-lbs./cycle (Nm/cycle)	(E <sub>T-C</sub> ) Max. in.-lbs./hour (Nm/hr)			SA in. (mm)	SB in. (mm)	Rec. Bolt Size in. (mm)	
HD(A) 5.0 x 4	4	414,000	15,600,000	327,000	16,000,000	124,000	400	10.8	8.7	1 ¼	192
	(100)	(46 700)	(1 762 621)	(37 000)	(1 809 624)	(550 000)	(1 760)	(275)	(220)	(M30)	(87)
HD(A) 5.0 x 6	6	620,000	17,720,000	500,000	18,000,000	124,000	400	10.8	8.7	1 ¼	207
	(150)	(70 000)	(2 002 337)	(56 000)	(2 049 340)	(550 000)	(1 760)	(275)	(220)	(M30)	(94)
HD(A) 5.0 x 8	8	828,000	19,841,000	660,000	20,250,000	124,000	400	10.8	8.7	1 ¼	223
	(200)	(93 500)	(2 242 053)	(74 500)	(2 289 057)	(550 000)	(1 760)	(275)	(220)	(M30)	(101)
HD(A) 5.0 x 10	10	1,036,000	21,921,000	827,000	22,300,000	124,000	400	10.8	8.7	1 ¼	238
	(250)	(117 000)	(2 477 070)	(93 500)	(2 524 073)	(550 000)	(1 760)	(275)	(220)	(M30)	(108)
HD(A) 5.0 x 12	12	1,239,000	24,042,000	990,000	24,500,000	124,000	400	10.8	8.7	1 ¼	251
	(300)	(140 000)	(2 716 786)	(112 000)	(2 763 789)	(550 000)	(1 760)	(275)	(220)	(M30)	(114)
HD 5.0 x 16	16	1,655,000	28,285,000	—	—	124,000	400	10.8	8.7	1 ¼	282
	(400)	(187 000)	(3 196 219)	—	—	(550 000)	(1 760)	(250)	(197)	(M24)	(128)
HD 5.0 x 20	20	2,071,000	36,688,000	—	—	124,000	400	10.8	8.7	1 ¼	348
	(500)	(234 000)	(4 145 684)	—	—	(550 000)	(1 760)	(250)	(197)	(M24)	(158)
HD 5.0 x 24	24	2,478,000	40,930,000	—	—	124,000	400	10.8	8.7	1 ¼	377
	(600)	(280 000)	(4 625 117)	—	—	(550 000)	(1 760)	(250)	(197)	(M24)	(171)
HD 5.0 x 28	28	2,894,000	45,132,000	—	—	124,000	400	10.8	8.7	1 ¼	407
	(700)	(327 000)	(5 099 849)	—	—	(550 000)	(1 760)	(250)	(197)	(M24)	(185)
HD 5.0 x 32	32	3,310,000	49,374,000	—	—	124,000	400	10.8	8.7	1 ¼	437
	(800)	(374 000)	(5 579 282)	—	—	(550 000)	(1 760)	(250)	(197)	(M24)	(198)
HD 5.0 x 40	40	4,133,000	57,818,000	—	—	124,000	400	10.8	8.7	1 ¼	496
	(1 000)	(467 000)	(6 533 447)	—	—	(550 000)	(1 760)	(250)	(197)	(M24)	(225)
HD 5.0 x 48	48	3,700,000	66,262,000	—	—	92,000	400	10.8	8.7	1 ¼	534
	(1 200)	(418 000)	(7 487 613)	—	—	(410 000)	(1 760)	(250)	(197)	(M24)	(242)

# Heavy Duty Series Shock Absorber

## HD/HDA Series

### Technical Data

HD(A) 5.0 x 4 → HD 5.0 x 48 Series

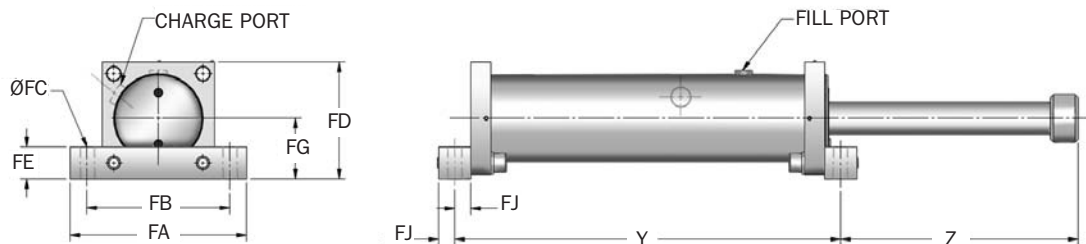

Note: For TF, FF and FR mounting, delete front foot and dimensions.

Catalog No./ Model	A in. (mm)	B in. (mm)	D in. (mm)	E in. (mm)	HD F in. (mm)	HDA F in. (mm)	H in. (mm)	HD Y in. (mm)	HDA Y in. (mm)	HD Z in. (mm)	HDA Z in. (mm)	Foot Mount Dimensions						Charge Port Dimensions			
												FA in. (mm)	FB in. (mm)	FC in. (mm)	FD in. (mm)	FE in. (mm)	FG in. (mm)	FJ in. (mm)	CA in. (mm)	CB in. (mm)	CC deg.
HD(A) 5.0 x 4	23.3 (591)	8.5 (215)	3.1 (80)	4.9 (125)	14.8 (375)	15.2 (385)	1.6 (40)	17.1 (435)	17.5 (445)	7.4 (186)	7.0 (176)	15.7 (400)	13.4 (340)	1.3 (33)	10.9 (278)	2.4 (60)	5.5 (140)	1.2 (30)	9.1 (230)	4.6 (117)	25° (25°)
HD(A) 5.0 x 6	27.3 (693)	8.5 (215)	3.1 (80)	4.9 (125)	16.8 (426)	17.2 (436)	1.6 (40)	19.1 (486)	19.5 (496)	9.4 (237)	9.0 (227)	15.7 (400)	13.4 (340)	1.3 (33)	10.9 (278)	2.4 (60)	5.5 (140)	1.2 (30)	9.1 (230)	4.6 (117)	25° (25°)
HD(A) 5.0 x 8	31.3 (795)	8.5 (215)	3.1 (80)	4.9 (125)	18.8 (477)	19.2 (487)	1.6 (40)	21.1 (537)	21.5 (547)	11.4 (288)	11.0 (278)	15.7 (400)	13.4 (340)	1.3 (33)	10.9 (278)	2.4 (60)	5.5 (140)	1.2 (30)	9.1 (230)	4.6 (117)	25° (25°)
HD(A) 5.0 x 10	35.3 (895)	8.5 (215)	3.1 (80)	4.9 (125)	20.8 (527)	21.2 (537)	1.6 (40)	23.1 (587)	23.5 (597)	13.4 (338)	13.0 (328)	15.7 (400)	13.4 (340)	1.3 (33)	10.9 (278)	2.4 (60)	5.5 (140)	1.2 (30)	9.1 (230)	4.6 (117)	25° (25°)
HD(A) 5.0 x 12	39.3 (997)	8.5 (215)	3.1 (80)	4.9 (125)	22.8 (578)	23.2 (588)	1.6 (40)	25.1 (638)	25.5 (648)	15.4 (389)	15.0 (379)	15.7 (400)	13.4 (340)	1.3 (33)	10.9 (278)	2.4 (60)	5.5 (140)	1.2 (30)	9.1 (230)	4.6 (117)	25° (25°)
HD 5.0 x 16	47.3 (1 201)	8.5 (215)	3.1 (80)	4.9 (125)	26.8 (680)	-	1.6 (40)	29.1 (740)	-	19.4 (491)	-	15.7 (400)	13.4 (340)	1.3 (33)	10.9 (278)	2.4 (60)	5.5 (140)	1.2 (30)	9.1 (230)	4.6 (117)	25° (25°)
HD 5.0 x 20	59.2 (1 504)	8.5 (215)	3.1 (80)	4.9 (125)	34.7 (882)	-	1.6 (40)	37.1 (942)	-	23.3 (592)	-	15.7 (400)	13.4 (340)	1.3 (33)	10.9 (278)	2.4 (60)	5.5 (140)	1.2 (30)	13.0 (230)	4.6 (117)	25° (25°)
HD 5.0 x 24	67.2 (1 708)	8.5 (215)	3.1 (80)	4.9 (125)	38.7 (984)	-	1.6 (40)	41.1 (1 044)	-	27.3 (694)	-	15.7 (400)	13.4 (340)	1.3 (33)	10.9 (278)	2.4 (60)	5.5 (140)	1.2 (30)	13.0 (230)	4.6 (117)	25° (25°)
HD 5.0 x 28	75.2 (1 910)	8.5 (215)	3.1 (80)	4.9 (125)	42.7 (1 085)	-	1.6 (40)	45.1 (1 145)	-	31.3 (795)	-	15.7 (400)	13.4 (340)	1.3 (33)	10.9 (278)	2.4 (60)	5.5 (140)	1.2 (30)	13.0 (230)	4.6 (117)	25° (25°)
HD 5.0 x 32	83.2 (2 114)	8.5 (215)	3.1 (80)	4.9 (125)	46.7 (1 187)	-	1.6 (40)	49.1 (1 247)	-	35.3 (897)	-	15.7 (400)	13.4 (340)	1.3 (33)	10.9 (278)	2.4 (60)	5.5 (140)	1.2 (30)	13.0 (230)	4.6 (117)	25° (25°)
HD 5.0 x 40	99.2 (2 520)	8.5 (215)	3.1 (80)	4.9 (125)	54.7 (1 390)	-	1.6 (40)	57.1 (1 450)	-	43.3 (1 100)	-	15.7 (400)	13.4 (340)	1.3 (33)	10.9 (278)	2.4 (60)	5.5 (140)	1.2 (30)	13.0 (230)	4.6 (117)	25° (25°)
HD 5.0 x 48	115.0 (2 920)	8.5 (215)	3.1 (80)	4.9 (125)	62.6 (1 590)	-	1.6 (40)	65.0 (1 650)	-	51.3 (1 300)	-	15.7 (400)	13.4 (340)	1.3 (33)	10.9 (278)	2.4 (60)	5.5 (140)	1.2 (30)	13.0 (230)	4.6 (117)	25° (25°)

- Notes: 1. HD shock absorbers will function satisfactorily at 5% of their maximum rated energy per cycle.  
 HDA models will function satisfactorily at 10% of their maximum rated energy per cycle. If less than these values, a smaller model should be specified.  
 2. It is recommended that the customer consult Enidine for safety-related overhead crane applications.  
 3. The energy data listed is for ideal linear impacts only. If side load conditions exist in the application, contact Enidine for sizing assistance.  
 4. Rear flange mounting of 12 inch strokes and longer not recommended. Front and rear flange or foot mount configurations are recommended.  
 5. HDA models which have an impact velocity below 30 in./sec., please contact Enidine for sizing assistance.  
 6. Maximum cycle rate is 60 cycles/hr.  
 7. For impact velocities over 180 in./sec. (4.5 m/s), consult factory.

HD(A) 6.0 x 4 → HD 6.0 x 48 Series

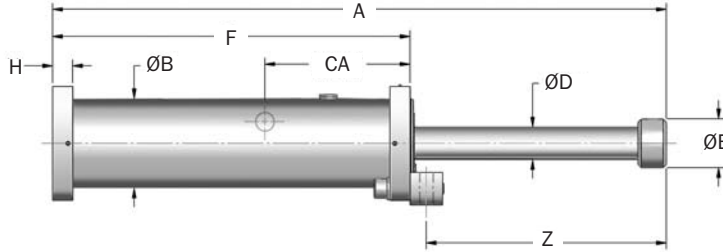
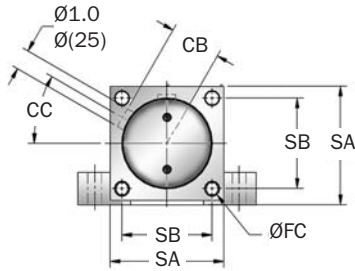

Note: For TF, FF and FR mounting, delete front foot and dimensions.

Catalog No./ Model	(S) Stroke in. (mm)	HD		HDA		(F <sub>P</sub> ) Max. Shock Force lbs. (N)	Nominal Return Force lbs. (N)	Flange Dimensions			Model Weight lbs. (Kg)
		(E <sub>T</sub> ) Max. in.-lbs./cycle (Nm/cycle)	(E <sub>C</sub> ) Max. in.-lbs./hour (Nm/hr)	(E <sub>T</sub> ) Max. in.-lbs./cycle (Nm/cycle)	(E <sub>C</sub> ) Max. in.-lbs./hour (Nm/hr)			SA in. (mm)	SB in. (mm)	Rec. Bolt Size in. (mm)	
HD(A) 6.0 x 4	4 (100)	677,000 (76 500)	21,280,000 (2 404 568)	540,000 (61 000)	22,000,000 (2 464 532)	202,250 (900 000)	625 (2 750)	13.0 (330)	10.2 (260)	1 ½ (M36)	362 (164)
HD(A) 6.0 x 6	6 (150)	1,010,000 (114 000)	23,933,000 (2 704 389)	810,000 (91 500)	24,500,000 (2 764 353)	202,250 (900 000)	625 (2 750)	13.0 (330)	10.2 (260)	1 ½ (M36)	386 (175)
HD(A) 6.0 x 8	8 (200)	1,354,000 (153 000)	26,586,000 (3 004 211)	1,080,000 (122 000)	27,000,000 (3 064 175)	202,250 (900 000)	625 (2 750)	13.0 (330)	10.2 (260)	1 ½ (M36)	410 (186)
HD(A) 6.0 x 10	10 (250)	1,690,000 (191 000)	29,345,000 (3 316 025)	1,350,000 (152 500)	30,000,000 (3 375 989)	202,250 (900 000)	625 (2 750)	13.0 (330)	10.2 (260)	1 ½ (M36)	432 (196)
HD(A) 6.0 x 12	12 (300)	1,982,000 (224 000)	32,052,000 (3 621 843)	1,620,000 (183 000)	33,000,000 (3 681 807)	202,250 (900 000)	625 (2 750)	13.0 (330)	10.2 (260)	1 ½ (M36)	456 (207)
HD 6.0 x 16	16 (400)	2,708,000 (306 000)	37,465,000 (4 233 478)	-	-	202,250 (900 000)	625 (2 750)	13.0 (330)	10.2 (260)	1 ½ (M36)	503 (228)
HD 6.0 x 20	20 (500)	3,380,000 (382 000)	42,877,000 (4 845 114)	-	-	202,250 (900 000)	625 (2 750)	13.0 (330)	10.2 (260)	1 ½ (M36)	551 (250)
HD 6.0 x 24	24 (600)	4,062,000 (459 000)	53,862,000 (6 086 375)	-	-	202,250 (900 000)	625 (2 750)	13.0 (330)	10.2 (260)	1 ½ (M36)	681 (309)
HD 6.0 x 30	30 (750)	5,070,000 (573 000)	61,928,000 (6 997 832)	-	-	202,250 (900 000)	625 (2 750)	13.0 (330)	10.2 (260)	1 ½ (M36)	752 (341)
HD 6.0 x 36	36 (900)	6,093,000 (688 500)	70,047,000 (7 915 285)	-	-	202,250 (900 000)	625 (2 750)	13.0 (330)	10.2 (260)	1 ½ (M36)	822 (373)
HD 6.0 X 42	42 (1 050)	7,106,000 (803 000)	78,113,000 (8 826 743)	-	-	202,250 (900 000)	625 (2 750)	13.0 (330)	10.2 (260)	1 ½ (M36)	893 (405)
HD 6.0 x 48	48 (1 200)	7,125,000 (805 000)	86,232,000 (9 744 196)	-	-	178,000 (790 000)	625 (2 750)	13.0 (330)	10.2 (260)	1 ½ (M36)	966 (438)

# Heavy Duty Series Shock Absorber

## HD/HDA Series

### Technical Data

HD(A) 6.0 x 4 → HD 6.0 x 48 Series

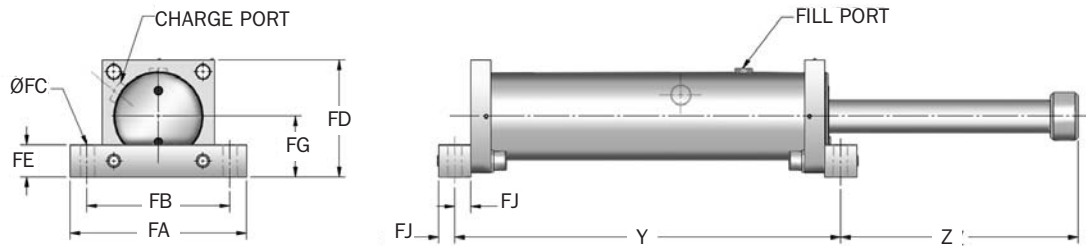

Note: For TF, FF and FR mounting, delete front foot and dimensions.

Catalog No./ Model	A in. (mm)	B in. (mm)	D in. (mm)	E in. (mm)	HD F in. (mm)	HDA F in. (mm)	H in. (mm)	HD Y in. (mm)	HDA Y in. (mm)	HD Z in. (mm)	HDA Z in. (mm)	Foot Mount Dimensions						Charge Port Dimensions			
												FA in. (mm)	FB in. (mm)	FC in. (mm)	FD in. (mm)	FE in. (mm)	FG in. (mm)	FJ in. (mm)	CA in. (mm)	CB in. (mm)	CC deg.
HD(A) 6.0 x 4	25.1 (637)	10.8 (275)	3.9 (100)	6.3 (160)	15.4 (391)	15.8 (401)	2.0 (50)	18.2 (461)	18.6 (471)	8.3 (211)	7.9 (201)	17.7 (450)	15.0 (380)	1.6 (40)	13.1 (333)	2.8 (70)	6.6 (168)	1.4 (35)	7.8 (197)	5.7 (144)	30° (30°)
HD(A) 6.0 x 6	29.1 (737)	10.8 (275)	3.9 (100)	6.3 (160)	17.4 (441)	17.8 (451)	2.0 (50)	20.2 (511)	20.6 (521)	10.3 (261)	9.9 (251)	17.7 (450)	15.0 (380)	1.6 (40)	13.1 (333)	2.8 (70)	6.6 (168)	1.4 (35)	7.8 (197)	5.7 (144)	30° (30°)
HD(A) 6.0 x 8	33.1 (839)	10.8 (275)	3.9 (100)	6.3 (160)	19.4 (492)	19.8 (502)	2.0 (50)	22.2 (562)	22.6 (572)	12.3 (312)	11.9 (302)	17.7 (450)	15.0 (380)	1.6 (40)	13.1 (333)	2.8 (70)	6.6 (168)	1.4 (35)	7.8 (197)	5.7 (144)	30° (30°)
HD(A) 6.0 x 10	37.1 (941)	10.8 (275)	3.9 (100)	6.3 (160)	21.4 (543)	21.8 (553)	2.0 (50)	24.2 (613)	24.6 (623)	14.3 (363)	13.9 (353)	17.7 (450)	15.0 (380)	1.6 (40)	13.1 (333)	2.8 (70)	6.6 (168)	1.4 (35)	7.8 (197)	5.7 (144)	30° (30°)
HD(A) 6.0 x 12	41.1 (1043)	10.8 (275)	3.9 (100)	6.3 (160)	23.4 (594)	23.8 (604)	2.0 (50)	26.2 (664)	26.6 (674)	16.3 (414)	15.9 (404)	17.7 (450)	15.0 (380)	1.6 (40)	13.1 (333)	2.8 (70)	6.6 (168)	1.4 (35)	7.8 (197)	5.7 (144)	30° (30°)
HD 6.0 x 16	49.1 (1 246)	10.8 (275)	3.9 (100)	6.3 (160)	27.4 (696)	—	2.0 (50)	30.2 (766)	—	20.3 (515)	—	17.7 (450)	15.0 (380)	1.6 (40)	13.1 (333)	2.8 (70)	6.6 (168)	1.4 (35)	7.8 (197)	5.7 (144)	30° (30°)
HD 6.0 x 20	57.1 (1 450)	10.8 (275)	3.9 (100)	6.3 (160)	31.4 (798)	—	2.0 (50)	34.2 (868)	—	24.3 (617)	—	17.7 (450)	15.0 (380)	1.6 (40)	13.1 (333)	2.8 (70)	6.6 (168)	1.4 (35)	7.8 (197)	5.7 (144)	30° (30°)
HD 6.0 x 24	69.7 (1 769)	10.8 (275)	3.9 (100)	6.3 (160)	40.0 (1 015)	—	2.0 (50)	42.7 (1 085)	—	28.4 (719)	—	17.7 (450)	15.0 (380)	1.6 (40)	13.1 (333)	2.8 (70)	6.6 (168)	1.4 (35)	12.3 (312)	5.7 (144)	30° (30°)
HD 6.0 x 30	81.6 (2 073)	10.8 (275)	3.9 (100)	6.3 (160)	46.0 (1 167)	—	2.0 (50)	48.7 (1 237)	—	34.3 (871)	—	17.7 (450)	15.0 (380)	1.6 (40)	13.1 (333)	2.8 (70)	6.6 (168)	1.4 (35)	12.3 (312)	5.7 (144)	30° (30°)
HD 6.0 x 36	93.7 (2 379)	10.8 (275)	3.9 (100)	6.3 (160)	52.0 (1 320)	—	2.0 (50)	54.7 (1 390)	—	40.4 (1 024)	—	17.7 (450)	15.0 (380)	1.6 (40)	13.1 (333)	2.8 (70)	6.6 (168)	1.4 (35)	12.3 (312)	5.7 (144)	30° (30°)
HD 6.0 x 42	105.6 (2 683)	10.8 (275)	3.9 (100)	6.3 (160)	58.0 (1 472)	—	2.0 (50)	60.7 (1 542)	—	46.3 (1 176)	—	17.7 (450)	15.0 (380)	1.6 (40)	13.1 (333)	2.8 (70)	6.6 (168)	1.4 (35)	12.3 (312)	5.7 (144)	30° (30°)
HD 6.0 x 48	117.7 (2 989)	10.8 (275)	3.9 (100)	6.3 (160)	64.0 (1 625)	—	2.0 (50)	66.7 (1 695)	—	52.4 (1 329)	—	17.7 (450)	15.0 (380)	1.6 (40)	13.1 (333)	2.8 (70)	6.6 (168)	1.4 (35)	12.3 (312)	5.7 (144)	30° (30°)

- Notes: 1. HD shock absorbers will function satisfactorily at 5% of their maximum rated energy per cycle.  
HDA models will function satisfactorily at 10% of their maximum rated energy per cycle. If less than these values, a smaller model should be specified.  
2. It is recommended that the customer consult Enidine for safety-related overhead crane applications.  
3. The energy data listed is for ideal linear impacts only. If side load conditions exist in the application, contact Enidine for sizing assistance.  
4. Rear flange mounting of 12 inch strokes and longer not recommended. Front and rear flange or foot mount configurations are recommended.  
5. For impact velocities over 180 in./sec. (4.5 m/s), consult factory.

Heavy Duty Series

HD(A) 3.0 x 2 → HD(A) 5.0 x 12 Series

**Clevis Mounts (CM)**

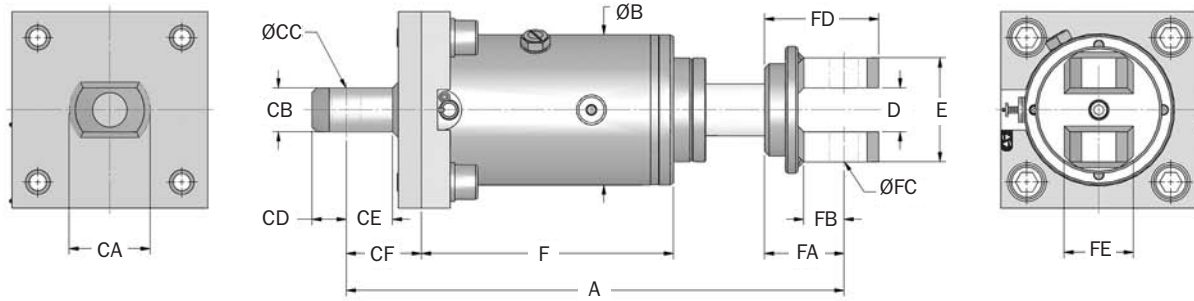

Note: Piston clevis dimensions are typical both ends on HD(A) 4.0 models.

Catalog No./ Model	Shock Absorber Dimensions						Cylinder Clevis Dimensions						Piston Clevis Dimensions				
	A in. (mm)	B in. (mm)	D in. (mm)	E in. (mm)	F in. (mm)	HDA F in. (mm)	CA in. (mm)	CB in. (mm)	CC in. (mm)	CD in. (mm)	CE in. (mm)	CF in. (mm)	FA in. (mm)	FB in. (mm)	FC in. (mm)	FD in. (mm)	FE in. (mm)
HD(A) 3.0 x 2	17.0 (432)	5.1 (130)	1.5 (38)	3.5 (90)	8.2 (209)	8.6 (219)	2.4 (60)	1.5 (38)	1.0 (25)	1.2 (30)	1.5 (37)	2.6 (65)	2.7 (69)	1.3 (32)	1.0 (25)	3.9 (99)	2.0 (50)
HD(A) 3.0 x 3	19.0 (483)	5.1 (130)	1.5 (38)	3.5 (90)	9.2 (235)	9.6 (245)	2.4 (60)	1.5 (38)	1.0 (25)	1.2 (30)	1.5 (37)	2.6 (65)	2.7 (69)	1.3 (32)	1.0 (25)	3.9 (99)	2.0 (50)
HD(A) 3.0 x 5	23.0 (585)	5.1 (130)	1.5 (38)	3.5 (90)	11.2 (286)	11.6 (296)	2.4 (60)	1.5 (38)	1.0 (25)	1.2 (30)	1.5 (37)	2.6 (65)	2.7 (69)	1.3 (32)	1.0 (25)	3.9 (99)	2.0 (50)
HD(A) 3.0 x 8	29.0 (736)	5.1 (130)	1.5 (38)	3.5 (90)	14.2 (361)	14.6 (371)	2.4 (60)	1.5 (38)	1.0 (25)	1.2 (30)	1.5 (37)	2.6 (65)	2.7 (69)	1.3 (32)	1.0 (25)	3.9 (99)	2.0 (50)
HD(A) 3.0 x 10	33.0 (838)	5.1 (130)	1.5 (38)	3.5 (90)	16.2 (412)	-	2.4 (60)	1.5 (38)	1.0 (25)	1.2 (30)	1.5 (37)	2.6 (65)	2.7 (69)	1.3 (32)	1.0 (25)	3.9 (99)	2.0 (50)
HD(A) 3.0 x 12	37.0 (940)	5.1 (130)	1.5 (38)	3.5 (90)	16.8 (463)	17.2 (473)	2.4 (60)	1.5 (38)	1.0 (25)	1.2 (30)	1.5 (37)	2.6 (65)	2.7 (69)	1.3 (32)	1.0 (25)	3.9 (99)	2.0 (50)
HD(A) 4.0 x 2	22.4 (570)	7.9 (200)	2.6 (65)	5.5 (140)	12.0 (304)	12.4 (314)	-	-	-	-	-	3.5 (90)	3.9 (100)	2.0 (50)	2.0 (50)	5.9 (150)	3.9 (100)
HD(A) 4.0 x 4	26.4 (672)	7.9 (200)	2.6 (65)	5.5 (140)	14.0 (355)	14.4 (365)	-	-	-	-	-	3.5 (90)	3.9 (100)	2.0 (50)	2.0 (50)	5.9 (150)	3.9 (100)
HD(A) 4.0 x 6	30.4 (772)	7.9 (200)	2.6 (65)	5.5 (140)	16.0 (405)	16.4 (415)	-	-	-	-	-	3.5 (90)	3.9 (100)	2.0 (50)	2.0 (50)	5.9 (150)	3.9 (100)
HD(A) 4.0 x 8	34.4 (875)	7.9 (200)	2.6 (65)	5.5 (140)	18.0 (457)	18.4 (467)	-	-	-	-	-	3.5 (90)	3.9 (100)	2.0 (50)	2.0 (50)	5.9 (150)	3.9 (100)
HD(A) 4.0 x 10	38.4 (976)	7.9 (200)	2.6 (65)	5.5 (140)	20.0 (507)	20.4 (517)	-	-	-	-	-	3.5 (90)	3.9 (100)	2.0 (50)	2.0 (50)	5.9 (150)	3.9 (100)
HD(A) 5.0 x 4	29.6 (751)	8.5 (215)	2.8 (70)	5.9 (150)	15.2 (386)	15.6 (396)	-	-	-	-	-	3.9 (100)	4.5 (115)	2.8 (70)	2.3 (60)	6.9 (175)	3.9 (100)
HD(A) 5.0 x 6	33.6 (853)	8.5 (215)	2.8 (70)	5.9 (150)	17.2 (437)	17.6 (447)	-	-	-	-	-	3.9 (100)	4.5 (115)	2.8 (70)	2.3 (60)	6.9 (175)	3.9 (100)
HD(A) 5.0 x 8	37.6 (955)	8.5 (215)	2.8 (70)	5.9 (150)	19.2 (488)	19.6 (498)	-	-	-	-	-	3.9 (100)	4.5 (115)	2.8 (70)	2.3 (60)	6.9 (175)	3.9 (100)
HD(A) 5.0 x 10	41.6 (1055)	8.5 (215)	2.8 (70)	5.9 (150)	21.2 (538)	21.6 (548)	-	-	-	-	-	3.9 (100)	4.5 (115)	2.8 (70)	2.3 (60)	6.9 (175)	3.9 (100)
HD(A) 5.0 x 12	45.6 (1157)	8.5 (215)	2.8 (70)	5.9 (150)	23.2 (589)	23.6 (599)	-	-	-	-	-	3.9 (100)	4.5 (115)	2.8 (70)	2.3 (60)	6.9 (175)	3.9 (100)





Enidine's **Heavy Industry (HI) Series** buffers safely protect heavy machinery and equipment during the transfer of materials and movement of products. The large-bore, high-capacity buffers are individually designed to decelerate moving loads under various conditions and in compliance with industry mandated safety standards. Control of bridge cranes, trolley platforms, large container transfer and transportation safety stops are typical installations. Industry-proven design technologies, coupled with the experience of a globally installed product base, ensure deliverable performance that exceeds customer expectations.

The oversize bore area results in optimal energy absorption capabilities and increased internal safety factors. State-of-the-art testing facilities ensure integrity of design and product performance.

HI Series

## Features and Benefits

- Compact design smoothly and safely decelerates large energy capacity loads up to 4 million in-lbs. per cycle with standard stroke lengths.
- Engineered to meet OSHA, AISE, CMMA and other safety specifications such as DIN and FEM.
- Nitrogen-charged return system allows for soft deceleration and positive return in a maintenance-free package.
- Wide variety of optional configurations including protective bellows and safety cables.
- Available in custom-orificed non-adjustable models.
- Special epoxy painting and rod materials are available for use in highly corrosive environments.
- Surface treatment (Sea water resistant)  
Housing: gray color, three-part epoxy  
Piston Rod: hard-chrome plated steel
- Incorporating optional fluids and seal packages available to expand standard operating temperature range from (0°F to 175°F) to (-30°F to 250°F).

### Enidine Heavy Industry (HI) Series Buffers

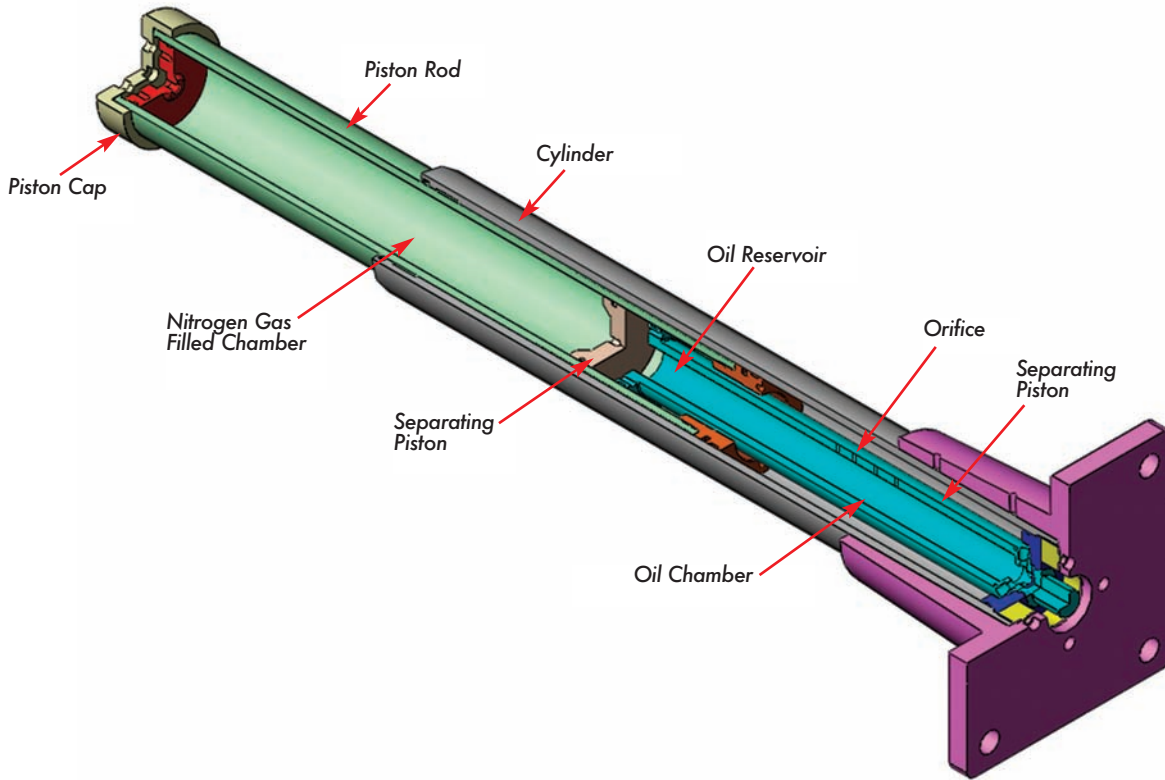

Enidine's Heavy Industry Series (HI) buffers safely protect heavy machinery and equipment during the transfer of materials and movement of products. The large-bore, high-capacity buffers are individually designed to decelerate moving loads under various conditions and in compliance with industry mandated safety standards. Control of bridge cranes, trolley platforms, large container transfer and transportation safety stops are typical installation examples. Industry-proven design technologies, coupled with the experience of a globally installed product base, ensure deliverable performance that exceeds customer expectations.

Prior to HI Series buffer manufacture, computer-simulated response curves are generated to model actual conditions, verify product performance, confirm damping characteristics and generate unique custom-orificed designs that accommodate multi-condition or specific damping requirements.

Characteristics of the HI Series include a nitrogen-charged return system that allows for soft deceleration and positive return in a maintenance-free package. The oversize bore area results in optimal energy absorption capabilities and increased internal safety factors. State-of-the-art testing facilities ensure integrity of design and product performance.

### Ordering Example

Mounting bracket flange:  
Standard: Rear or Front mount

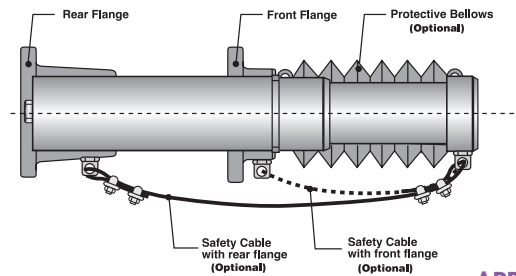

Example:

**4**

Select quantity

**HI 120 x 100**

Select HI Series model from  
Engineering Data Chart

**FR**

Select mounting method  
• FF (Flange Front)  
• FR (Flange Rear)

**B**

Additional Options  
• B Protective Bellows  
• C Safety cable

#### APPLICATION DATA

Required for all models:

- Vertical/Horizontal Motion
- Weight
- Impact Velocity
- Propelling Force (if any)
- Cycles/Hour
- Temperature/Environment
- Applicable Standards

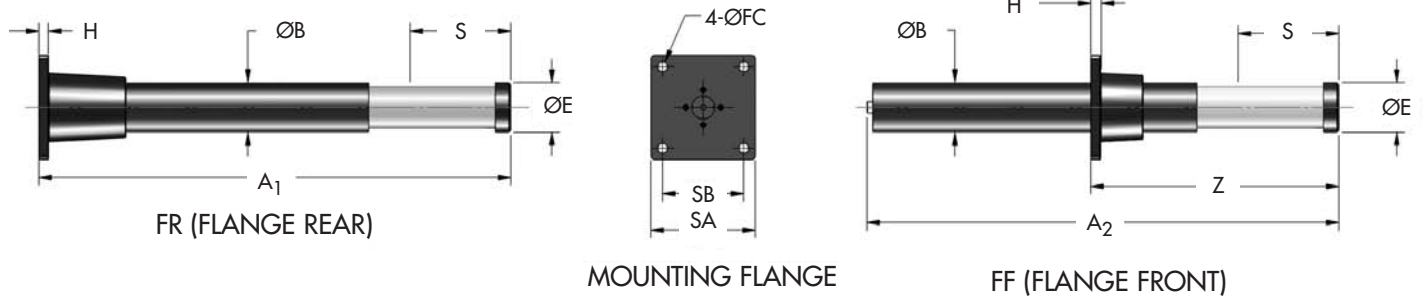

Catalog No./Model	S Stroke in. (mm)	Max. Energy/cycle in.-lbs. (Nm)	Max. Shock Force lbs. (kN)	Return Force		Weight lbs. (Kg)	A <sub>1</sub> in. (mm)	A <sub>2</sub> in. (mm)	Z in. (mm)	H in. (mm)	ØB in. (mm)	SA in. (mm)	SB in. (mm)	ØFC in. (mm)	BOLT SIZE in. (mm)	ØE in. (mm)
				Extension lbs. (kN)	Compression lbs. (kN)											
HI 50 x 50	2 (50)	27,000 (3 050)	15,000 (67)	70 (0,3)	140 (0,6)	11 (5)	10.3 (262)	—	—	0.6 (15)	2.36 (60)	3.94 (100)	2.76 (70)	0.59 (15)	1/2 (M14)	2.28 (58)
HI 50 x 100	3.9 (100)	55,500 (6 200)	15,000 (67)	70 (0,3)	140 (0,6)	20 (9)	15.4 (392)	—	—	0.6 (15)	2.36 (60)	3.94 (100)	2.76 (70)	0.59 (15)	1/2 (M14)	2.28 (58)
HI 80 x 50	2 (50)	60,000 (6 700)	37,750 (168)	225 (1,0)	430 (1,9)	33 (15)	11.4 (290)	—	—	0.6 (15)	3.15 (80)	5.04 (128)	3.50 (89)	0.79 (20)	3/4 (M18)	3.11 (79)
HI 80 x 100	3.9 (100)	120,000 (13 500)	37,750 (168)	225 (1,0)	1,800 (8,0)	42 (19)	15.4 (390)	—	—	0.6 (15)	3.15 (80)	5.04 (128)	3.50 (89)	0.79 (20)	3/4 (M18)	3.11 (79)
HI 100 x 50	2 (50)	88,500 (10 000)	56,200 (250)	370 (1,65)	4,050 (18,0)	36 (16)	11.9 (302)	11.9 (301)	6.9 (175)	0.8 (20)	3.94 (100)	5.91 (150)	4.72 (120)	0.71 (18)	5/8 (M16)	3.90 (99)
HI 100 x 100	3.9 (100)	177,000 (20 000)	56,200 (250)	370 (1,65)	4,050 (18,0)	49 (22)	18.9 (479)	18.6 (473)	9.7 (245)	0.8 (20)	3.94 (100)	5.91 (150)	4.72 (120)	0.71 (18)	5/8 (M16)	3.90 (99)
HI 100 x 150	5.9 (150)	265,500 (30 000)	56,200 (250)	370 (1,65)	4,050 (18,0)	62 (28)	24.3 (618)	24.1 (612)	11.8 (300)	0.8 (20)	3.94 (100)	5.91 (150)	4.72 (120)	0.71 (18)	5/8 (M16)	3.90 (99)
HI 100 x 200	7.9 (200)	354,000 (40 000)	56,200 (250)	370 (1,65)	4,050 (18,0)	71 (32)	29.8 (756)	29.5 (750)	15.4 (390)	0.8 (20)	3.94 (100)	5.91 (150)	4.72 (120)	0.71 (18)	5/8 (M16)	3.90 (99)
HI 100 x 400	15.7 (400)	708,060 (80 000)	52,830 (235)	370 (1,65)	4,050 (18,0)	101 (46)	53.1 (1 349)	53.0 (1 345)	25.4 (645)	1.0 (25)	3.94 (100)	5.91 (150)	4.72 (120)	0.71 (18)	5/8 (M16)	3.90 (99)
HI 100 x 500	19.7 (500)	831,900 (94 000)	52,800 (235)	370 (1,65)	4,050 (18,0)	115 (52)	—	63.6 (1 616)	35.0 (890)	0.8 (20)	3.94 (100)	5.91 (150)	4.72 (120)	0.71 (18)	5/8 (M16)	3.90 (99)
HI 100 x 600	23.6 (600)	991,200 (112 000)	51,700 (230)	370 (1,65)	4,050 (18,0)	128 (58)	—	74.3 (1 888)	40.9 (1 040)	0.8 (20)	3.94 (100)	5.91 (150)	4.72 (120)	0.71 (18)	5/8 (M16)	3.90 (99)
HI 100 x 800	31.5 (800)	1,168,200 (132 000)	46,085 (205)	370 (1,65)	4,050 (18,0)	152 (69)	—	95.5 (2 426)	53.0 (1 345)	0.8 (20)	3.94 (100)	5.91 (150)	4.72 (120)	0.71 (18)	5/8 (M16)	3.90 (99)
HI 120 x 100	3.9 (100)	283,200 (32 000)	89,920 (400)	630 (2,8)	11,250 (50,0)	75 (34)	18.5 (471)	18.4 (467)	10.6 (270)	0.8 (20)	4.72 (120)	8.66 (220)	6.69 (170)	1.02 (26)	1 (M24)	4.69 (119)
HI 120 x 150	5.9 (150)	424,800 (48 000)	89,920 (400)	630 (2,8)	11,250 (50,0)	86 (39)	23.5 (597)	23.3 (593)	13.0 (330)	0.8 (20)	4.72 (120)	8.66 (220)	6.69 (170)	1.02 (26)	1 (M24)	4.69 (119)
HI 120 x 200	7.9 (200)	566,400 (64 000)	89,920 (400)	630 (2,8)	11,250 (50,0)	95 (43)	28.5 (724)	28.3 (720)	15.4 (390)	0.8 (20)	4.72 (120)	8.66 (220)	6.69 (170)	1.02 (26)	1 (M24)	4.69 (119)
HI 120 x 300	11.8 (300)	831,900 (94 000)	89,920 (400)	630 (2,8)	11,250 (50,0)	117 (53)	38.3 (973)	38.1 (969)	20.5 (520)	0.8 (20)	4.72 (120)	8.66 (220)	6.69 (170)	1.02 (26)	1 (M24)	4.69 (119)
HI 120 x 400	15.7 (400)	1,106,300 (125 000)	89,920 (400)	630 (2,8)	11,250 (50,0)	192 (87)	48.2 (1 225)	48.1 (1 221)	26.8 (680)	1.0 (25)	4.72 (120)	8.66 (220)	6.69 (170)	1.02 (26)	1 (M24)	4.69 (119)
HI 120 x 600	23.6 (600)	1,663,900 (188 000)	89,920 (400)	630 (2,8)	11,250 (50,0)	232 (105)	—	67.9 (1 725)	36.0 (915)	1.0 (25)	4.72 (120)	8.66 (220)	6.69 (170)	1.02 (26)	1 (M24)	4.69 (119)
HI 120 x 800	31.5 (800)	1,991,250 (225 000)	78,690 (350)	630 (2,8)	11,250 (50,0)	243 (110)	—	91.8 (2 332)	50.8 (1 290)	1.0 (25)	4.72 (120)	8.66 (220)	6.69 (170)	1.02 (26)	1 (M24)	4.69 (119)
HI 120 x 1000	39.4 (1000)	2,301,000 (260 000)	73,060 (325)	630 (2,8)	11,250 (50,0)	256 (116)	—	111.7 (2 836)	53.5 (1 360)	1.0 (25)	4.72 (120)	8.66 (220)	6.69 (170)	1.02 (26)	1 (M24)	4.69 (119)

# Heavy Industry Shock Absorbers

## HI Series

HI 130 x 250 → HI 150 x 1000 Series

### Technical Data

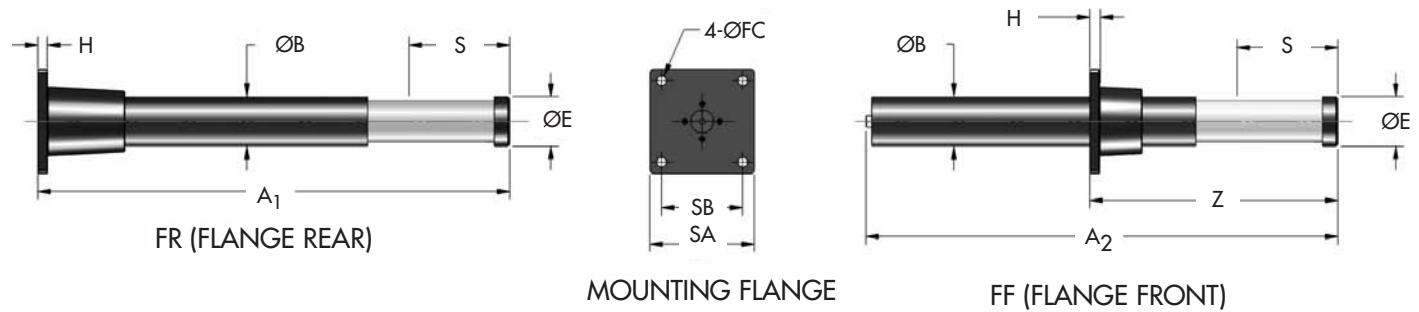

Catalog No./ Model	Max. S Stroke in. (mm)	Max. Energy/cycle in.-lbs. (Nm)	Shock Force lbs. (kN)	Return Force		Weight lbs. (Kg)	A <sub>1</sub> in. (mm)	A <sub>2</sub> in. (mm)	Z in. (mm)	H in. (mm)	ØB in. (mm)	SA in. (mm)	SB in. (mm)	ØFC in. (mm)	BOLT SIZE in. (mm)	ØE in. (mm)
				Extension lbs. (kN)	Compression lbs. (kN)											
HI 130 x 250	9.8 (250)	885,000 (100 000)	112,400 (500)	720 (3,2)	14,400 (64,0)	159 (72)	35.3 (897)	35.2 (893)	21.5 (545)	1.0 (25)	5.12 (130)	10.63 (270)	8.27 (210)	1.02 (26)	1 (M24)	5.08 (129)
HI 130 x 300	11.8 (300)	1,062,000 (120 000)	112,400 (500)	720 (3,2)	14,400 (64,0)	175 (79)	40.5 (1 029)	40.4 (1 025)	23.8 (605)	1.0 (25)	5.12 (130)	10.63 (270)	8.27 (210)	1.02 (26)	1 (M24)	5.08 (129)
HI 130 x 400	15.7 (400)	1,416,100 (160 000)	112,400 (500)	720 (3,2)	14,400 (64,0)	199 (90)	50.9 (1 293)	50.8 (1 289)	28.9 (735)	1.0 (25)	5.12 (130)	10.63 (270)	8.27 (210)	1.02 (26)	1 (M24)	5.08 (129)
HI 130 x 600	23.6 (600)	1,858,500 (210 000)	97,790 (435)	720 (3,2)	14,400 (64,0)	263 (119)	— (—)	75.5 (1 917)	41.7 (1 060)	1.0 (25)	5.12 (130)	10.63 (270)	8.27 (210)	1.02 (26)	1 (M24)	5.08 (129)
HI 130 x 800	31.5 (800)	2,388,500 (270 000)	94,415 (420)	720 (3,2)	14,400 (64,0)	309 (140)	— (—)	96.3 (2 445)	53.2 (1 350)	1.0 (25)	5.12 (130)	10.63 (270)	8.27 (210)	1.02 (26)	1 (M24)	5.08 (129)
HI 150 x 115	4.5 (115)	548,700 (62 000)	150,600 (670)	1,125 (5,0)	21,600 (96,0)	124 (56)	20.4 (517)	20.2 (513)	12.6 (320)	0.8 (20)	5.91 (150)	10.63 (270)	8.27 (210)	1.02 (26)	1 (M24)	5.87 (149)
HI 150 x 150	5.9 (150)	725,700 (82 000)	150,600 (670)	1,125 (5,0)	21,600 (96,0)	130 (59)	23.9 (606)	23.7 (602)	14.0 (355)	1.0 (25)	5.91 (150)	10.63 (270)	8.27 (210)	1.02 (26)	1 (M24)	5.87 (149)
HI 150 x 400	15.7 (400)	1,947,000 (220 000)	150,600 (670)	1,125 (5,0)	21,600 (96,0)	216 (98)	49.2 (1 249)	49.0 (1 245)	28.0 (710)	1.0 (25)	5.91 (150)	10.63 (270)	8.27 (210)	1.02 (26)	1 (M24)	5.87 (149)
HI 150 x 500	19.7 (500)	2,433,900 (275 000)	150,600 (670)	1,125 (5,0)	21,600 (96,0)	243 (110)	— (—)	59.0 (1 498)	30.3 (770)	1.0 (25)	5.91 (150)	10.63 (270)	8.27 (210)	1.02 (26)	1 (M24)	5.87 (149)
HI 150 x 600	23.6 (600)	2,920,500 (330 000)	150,600 (670)	1,125 (5,0)	21,600 (96,0)	265 (120)	— (—)	69.0 (1 752)	34.4 (875)	1.0 (25)	5.91 (150)	10.63 (270)	8.27 (210)	1.02 (26)	1 (M24)	5.87 (149)
HI 150 x 800	31.5 (800)	3,965,100 (448 000)	157,360 (700)	1,125 (5,0)	21,600 (96,0)	364 (165)	— (—)	93.0 (2 363)	48.8 (1 240)	1.0 (25)	5.91 (150)	10.63 (270)	8.27 (210)	1.02 (26)	1 (M24)	5.87 (149)
HI 150 x 1000	39.4 (1000)	4,513,500 (510 000)	142,750 (635)	1,125 (5,0)	21,600 (96,0)	397 (180)	— (—)	113.4 (2 880)	62.8 (1 595)	1.0 (25)	5.91 (150)	10.63 (270)	8.27 (210)	1.02 (26)	1 (M24)	5.87 (149)



The design of Jarret Industrial Shock Absorber utilizes the unique compression and shear characteristics of specially formulated silicone elastomers.

These characteristics allow the energy absorption and return spring functions to be combined into a single unit **without the need for an additional gas or mechanical spring stroke return mechanism.**

### Applications

Shock protection for all types of industries including:  
**Defense, Automobile, Railroad, Materials Handling,  
 Marine, Pulp/Paper, Metal Producing and Processing.**

### Advantages:

- Simple design - High reliability
- High damping coefficient
- Low sensitivity to temperature variances

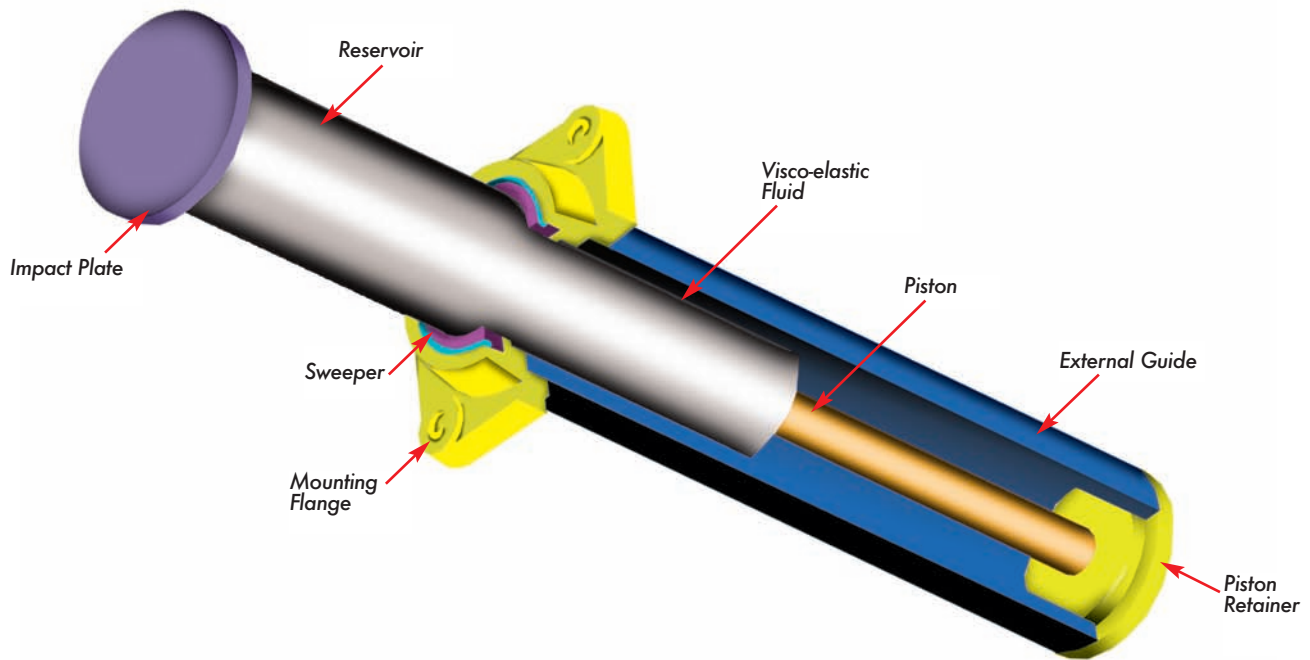

Visco-elastic technology makes use of the fundamental properties of specially formulated Jarret visco-elastic fluids.

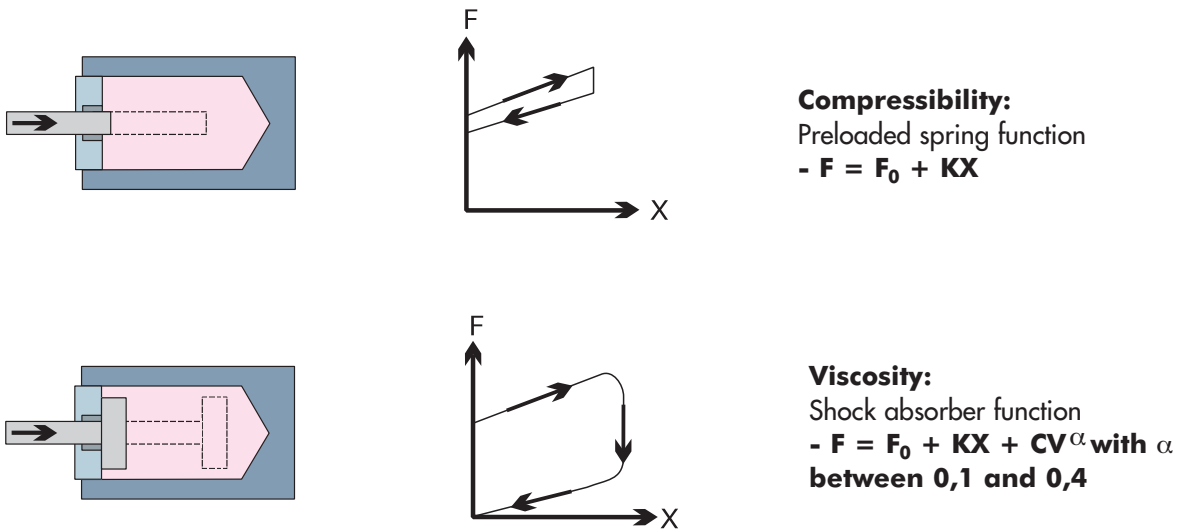

The two functions can be used separately or in combination, in the same product:

**Preloaded Spring:  
Spring Function Only**

- Hysteresis of between 5% and 10%
- Reduced weight and space requirement
- Force/stroke characteristic is independent of actuation speed

**Preloaded Spring Shock Absorbers:  
Combine Spring and Shock Absorber Functions**

- Dissipate between 30% and 100% of energy
- Force/stroke characteristics remain relatively unchanged between 15°F and 160°F (-10°C and + 70°C)

**Shock Absorber Without Spring Return:  
Shock Absorbing Function Only**

- Dampening devices
- Blocking Devices

BC1ZN → BC1GN Series

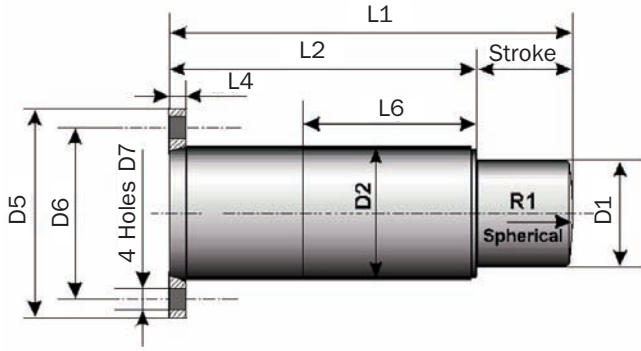

Rear flange mounting - Fa

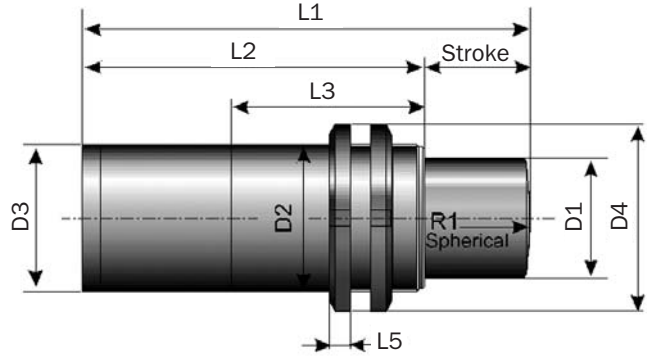

Threaded body mounting - Fc

Catalog No./ Model	Max Energy Capacity in-lbs. (kJ)	Stroke in. (mm)	Return Force		Rdy0 lbs. (kN)	Rdymax Max Shock Force lbs. (kN)
			Extension lbs. (kN)	Compression lbs. (kN)		
BC1ZN	885 (0,1)	0.47 (12)	211.3 (0,94)	1,213.97 (5,4)	1349 (6)	2473 (11)
BC1BN	3806 (0,43)	0.87 (22)	562 (2,5)	3,147.32 (14,0)	3,147 (14)	6070 (27)
BC1DN	13,276 (1,5)	1.4 (35)	1,169 (5,2)	6,474.5 (28,8)	6,295 (28)	13,489 (60)
BC1EN	30,093 (3,4)	1.8 (45)	1,753.5 (7,8)	9,666.78 (43,0)	10,116 (45)	22,481 (100)
BC1FN	61,955 (7)	2.4 (60)	3,057.4 (13,6)	17,220.36 (76,6)	20,233 (90)	33,721 (150)
BC1GN	123,910 (14)	3.1 (80)	4,271.4 (19,0)	29,225.16 (130,0)	29,225 (130)	51,706 (230)

Catalog No./ Model	L1 in. (mm)	L2 in. (mm)	L3 in. (mm)	L4 in. (mm)	L5 in. (mm)	L6 in. (mm)	R1 in. (mm)	D1 in. (mm)	D2 in. (mm)	D3 in. (mm)	D4 in. (mm)	D5 in. (mm)	D6 in. (mm)	D7 in. (mm)	Mass lbs. (kg.)
BC1ZN	2.95 (75)	2.1 (53)	2.1 (52)	0.39 (10)	0.28 (7)	1.7 (43)	— —	0.75 (19)	M25 x 1,5	0.79 (20)	1.5 (38)	2.2 (57)	1.6 (41)	0.28 (7)	0.7 (0,3)
BC1BN	4.7 (120)	3.9 (98)	3.8 (96)	0.47 (12)	0.31 (8)	3.4 (86)	— —	1.0 (25)	M35 x 1,5	1.3 (32)	2.0 (52)	3.1 (80)	2.4 (60)	0.35 (9)	1.5 (0,7)
BC1BN-M	4.7 (120)	3.9 (98)	3.8 (96)	0.47 (12)	0.35 (9)	— —	— —	1.0 (25)	M40 x 1,5	1.3 (32)	2.3 (58)	— —	— —	— —	1.8 (0,8)
BC1DN	6.9 (175)	5.5 (140)	5.4 (138)	0.47 (12)	0.43 (11)	5.0 (128)	— —	1.5 (38)	M50 x 1,5	1.8 (45)	2.8 (70)	3.5 (90)	2.8 (70)	0.35 (9)	4.2 (1,9)
BC1DN	6.9 (175)	5.5 (140)	5.4 (138)	0.47 (12)	0.43 (11)	5.0 (128)	— —	1.5 (38)	M50 x 1,5	1.8 (45)	2.8 (70)	4.2 (106)	3.3 (85)	0.43 (11)	4.4 (2)
BC1DN-M	6.9 (175)	5.5 (140)	5.4 (138)	0.47 (12)	0.43 (11)	— —	— —	1.5 (38)	M60 x 2	1.8 (45)	2.8 (70)	— —	— —	— —	4.4 (2)
BC1EN	8.4 (213)	6.6 (168)	6.2 (158)	0.39 (10)	0.51 (13)	6.2 (158)	R. 5.1 (R.130)	2.4 (60)	M75 x 2	2.8 (72)	3.9 (98)	4.8 (122)	4.0 (100)	0.43 (11)	11 (5)
BC1FN	10.6 (270)	8.3 (210)	5.1 (130)	0.47 (12)	0.63 (16)	5.1 (130)	R. 5.9 (R.150)	2.9 (74,5)	M90 x 2	3.5 (90)	4.7 (120)	5.9 (150)	4.7 (120)	0.51 (13)	23.1 (10,5)
BC1GN	13.3 (337)	10.1 (257)	5.7 (145)	0.55 (14)	0.75 (19)	5.7 (145)	R. 13.8 (R.350)	3.5 (90)	M110 x 2	4.3 (110)	5.7 (145)	6.9 (175)	5.6 (143)	0.70 (18)	37.5 (17)

# Jarret Shock Absorbers

## BC1N Series

### Application Worksheet

BC1ZN → BC1GN Series

#### 1 - Selection Chart

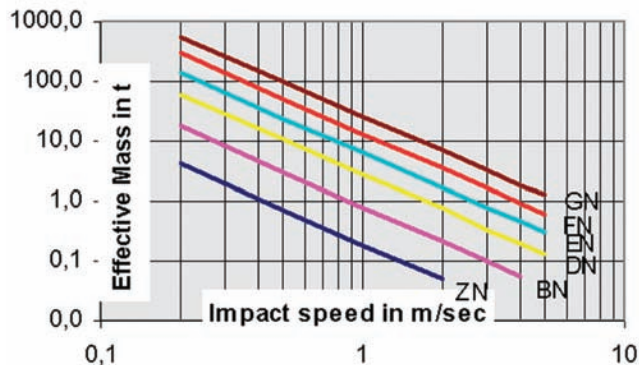

#### Based On

- Impact velocity : 2 m/s
- Operating temperature : - 20° to + 40°C
- Surface protection : Electrolytic zinc
- Dynamic performance diagram

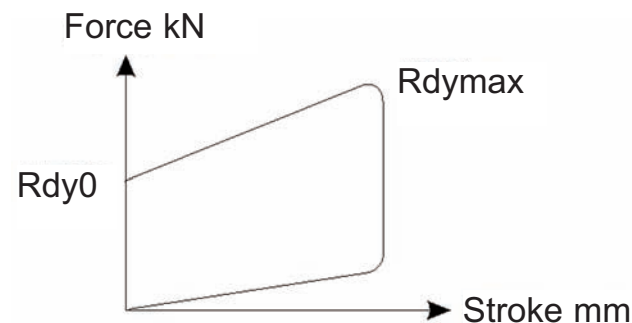

#### Symbols:

- En = Energy Capacity
- C = Maximum Stroke
- Rdy = Dynamic Reaction

#### 2 - Energy Calculation

$$E = \frac{1}{2} M_e V_e^2$$

#### 3 - Allowable Impact Velocity

$$F < 20 \times \frac{E_n}{E} \text{ Impacts/hour}$$

#### 4 - Effective Stroke Calculation

$$C_e = C \left( \sqrt{\frac{E}{E_n (0,03 V + 0,24)}} + 1,36 - 1,17 \right)$$

#### 5 - Calculation of Effective Reaction Rdy<sub>e</sub>

$$Rdy_e = \left[ \left( \frac{Rdy_{max} - Rdy_0}{C} \right) \times C_e + Rdy_0 \right] (0,1V + 0,8)$$

#### 6 - Application Example

Given data: Effective mass = 15 t,  
Effective speed = 0,8 m/s  
Impact frequency: 25 impacts/hour

- 1: BC1FN Selected
- 2: Energy dissipated per impact is: 4,8 kJ
- 3: Allowable impact frequency < 20x7/4.8
- 4: Required stroke is 49 mm

$$C_e = 60 \left( \sqrt{\frac{4,8}{7 (0,03 \times 0,8 + 0,24)}} + 1,36 - 1,17 \right)$$

5: With an Rdy<sub>e</sub> = [(150 - 90) x 49/60 + 90] x (0,1 x 0,8 + 0,8) = 122 kN

Compare with standard mechanical characteristics:

En = 7 kJ, C = 60mm, Rdy0 = 90 kN and Rdy<sub>max</sub> = 150 kN

**All performance characteristics can be modified. Please advise us of your specific requirements.**

BC5A → BC5E Series

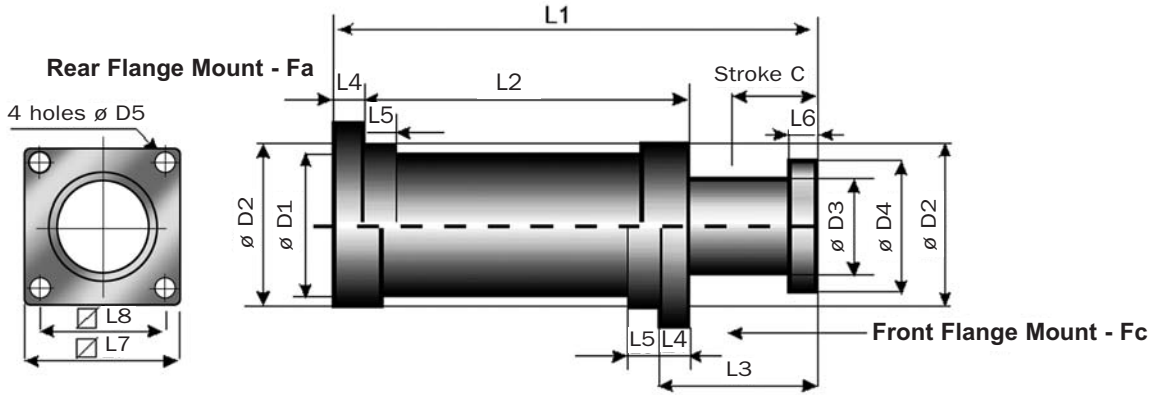

Catalog No./ Model	Max Energy Capacity in-lbs. (kJ)	Stroke in. (mm)	Return Force		Rdy0 lbs. (kN)	Rdymax Max Shock Force lbs. (kN)
			Extension lbs. (kN)	Compression lbs. (kN)		
BC5A	221,268 (25)	4.1 (105)	4,159 (18,5)	31,630 (140,7)	37,543 (167)	69,691 (310)
BC5B	442,537 (50)	4.7 (120)	13,039 (58,0)	58,416 (259,9)	69,691 (310)	121,397 (540)
BC5C	663,806 (75)	5.5 (140)	11,015 (49,0)	73,827 (328,4)	89,924 (400)	157,366 (700)
BC5D	885,075 (100)	6.3 (160)	13,376 (59,5)	85,427 (380,0)	105,660 (470)	184,343 (820)
BC5E	1,327,612 (150)	7.1 (180)	26,269 (117,0)	122,656 (546)	143,878 (640)	247,290 (1 100)

Catalog No./ Model	L1 in. (mm)	L2 in. (mm)	L3 in. (mm)	L4 in. (mm)	L5 in. (mm)	L6 in. (mm)	L7 in. (mm)	L8 in. (mm)	D1 in. (mm)	D2 in. (mm)	D3 in. (mm)	D4 in. (mm)	D5 in. (mm)	Mass lbs. (kg)
BC5A	16.3 (415)	10.8 (275)	5.5 (140)	0.79 (20)	1.2 (30)	0.59 (15)	5.3 (135)	4.1 (105)	4.6 (116)	4.6 (116)	3.4 (87)	4.7 (120)	0.55 (14)	55 (25)
BC5B	19.7 (500)	12.8 (325)	6.9 (175)	1.0 (25)	1.3 (33)	1.2 (30)	6.1 (155)	4.9 (125)	5.6 (142)	5.6 (142)	4.5 (115)	5.4 (138)	0.55 (14)	88 (40)
BC5C	20.5 (520)	12.4 (315)	8.1 (205)	1.2 (30)	1.4 (36)	1.4 (35)	6.9 (175)	5.5 (140)	6.3 (160)	6.3 (160)	5.2 (132)	6.2 (158)	0.70 (18)	99 (45)
BC5D	23 (585)	13.8 (350)	9.3 (235)	1.4 (35)	1.6 (40)	1.6 (40)	8.5 (215)	6.7 (170)	7.1 (180)	7.1 (180)	6.0 (153)	7.3 (185)	0.87 (22)	161 (73)
BC5E	26.4 (670)	15.9 (405)	10.4 (265)	1.6 (40)	1.8 (45)	1.8 (45)	9.8 (250)	7.7 (195)	8.5 (215)	8.5 (215)	7.2 (182)	8.7 (220)	1.0 (26)	258 (117)

Impact Speed: BC5 Series shock absorbers are designed for impact velocities of up to 4 m/sec. Higher impact velocities require custom modification.

# Jarret Shock Absorbers

## BC5 Series

BC5A → BC5E Series

### Application Worksheet

#### Based On

- Impact velocity : 2 m/s
- Operating temperature : - 20° to + 40°C
- Surface protection : Electrolytic zinc
- Dynamic performance diagram

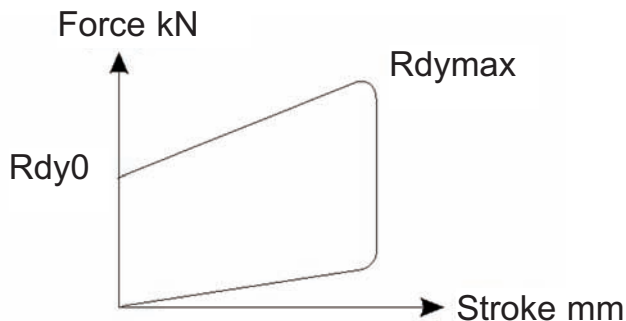

#### Symbols:

- En = Energy Capacity
- C = Maximum Stroke
- Rdy = Dynamic Reaction

#### 1 - Energy Calculation

$$E = \frac{1}{2} M_e V_e^2$$

#### 2 - Allowable Impact Velocity

$$F < 15 \times \frac{E_n}{E} \text{ Impacts/hour}$$

#### 3 - Effective Stroke Calculation

$$C_e = C \left( \sqrt{\frac{E}{E_n (0,03 V + 0,24)} + 1,36 - 1,17} \right)$$

#### 4 - Calculation of Effective Reaction Rdy<sub>e</sub>

$$Rdy_e = \left[ \left( \frac{Rdy_{max} - Rdy_0}{C} \right) \times C_e + Rdy_0 \right] (0,1V + 0,8)$$

#### 5 - Application Example

**Data:** Two shock absorbers in series, Effective mass  $m = 300 \text{ t}$ , Impact speed  $v = 1,2 \text{ m/s}$  (which is an impact of  $0,6 \text{ m/s}$  on each shock absorber), Impact frequency = 15 impacts/hour, Maximum allowable structural load 1000 kN

1:  $E = \frac{1}{2} \left( \frac{1}{2} mV^2 \right)$  - Selection BC5-E

2: Maximum allowable impact frequency is  $15 \times \frac{150}{108}$  21 impacts/hour. Therefore 15 impacts/hour is acceptable.

3: Required stroke is 167 mm

$$C_e = 180 \times \left( \sqrt{\frac{108}{150 (0,03 \times 0,6 + 0,24)} + 1,36 - 1,17} \right) = 156 \text{ mm}$$

4:  $Rdy_e = \left[ (1100 - 640) \times \frac{156}{180} + 640 \right] (0,1 \times 0,6 + 0,8)$   
 = 893 kN < 1000 kN, maximum allowable impact frequency

Compare with standard mechanical characteristics for each shock absorber:

$E_n = 150 \text{ kJ}$ ,  $C = 180 \text{ mm}$ ,  $Rdy_0 = 640 \text{ kN}$  and  
 $Rdy_{max} = 1100 \text{ kN}$

**All performance characteristics can be modified.  
 Please advise us of your specific requirements.**

XLR6-150 → XLR-800 Series

LR Series

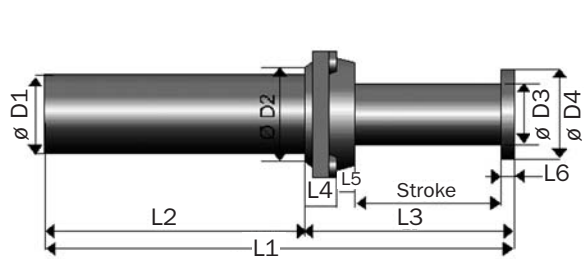

XLR Series - Front Flange Mount - Fc

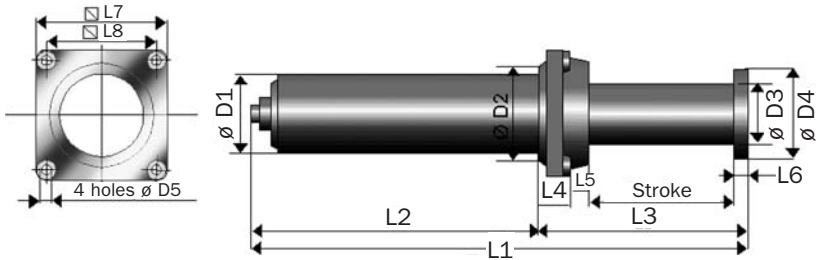

BCLR Series - Front Flange Mount - Fc

Catalog No./ Model	Max Energy Capacity in-lbs. (kJ)	Stroke in. (mm)	Return Force		Rdy0 lbs. (kN)	Rdymax Max Shock Force lbs. (kN)
			Extension lbs. (kN)	Compression lbs. (kN)		
<b>XLR6-150</b>	53,104 (6)	5.9 (150)	652 (2,9)	4,609 (20,5)	5,620 (25)	11,240 (50)
<b>XLR12-150</b>	106,209 (12)	5.9 (150)	1,866 (8,3)	8,655 (38,5)	14,837 (66)	22,481 (100)
<b>XLR12-200</b>	106,209 (12)	7.9 (200)	1,259 (5,6)	6,744 (30,0)	9,442 (42)	17,535 (78)
<b>XLR25-200</b>	221,269 (25)	7.9 (200)	3,012 (13,4)	16,726 (74,4)	21,537 (95)	33,721 (150)
<b>XLR25-270</b>	221,269 (25)	10.6 (270)	2,495 (11,1)	11,555 (51,4)	14,837 (66)	25,179 (112)
<b>XLR50-275</b>	442,537 (50)	10.8 (275)	4,429 (19,7)	29,225 (130,0)	26,527 (118)	51,706 (230)
<b>XLR50-400</b>	442,537 (50)	15.7 (400)	2,900 (12,9)	18,839 (83,8)	16,861 (75)	33,721 (150)
<b>XLR100-400</b>	885,075 (100)	15.7 (400)	5,620 (25,0)	36,531 (162,5)	39,342 (175)	71,939 (320)
<b>XLR100-600</b>	885,075 (100)	23.6 (600)	2,608 (11,6)	29,765 (132,4)	19,109 (85)	51,706 (230)
<b>XLR150-800</b>	1,327,612 (150)	31.5 (800)	5,216 (23,2)	34,216 (152,2)	17,984 (80)	56,202 (250)

Impact Speed: Types XLR and BCLR Series shock absorbers are designed for impact velocities of up to 2 m/sec. Higher impact velocities require custom modification.

Catalog No./ Model	L1 in. (mm)	L2 in. (mm)	L3 in. (mm)	L4 in. (mm)	L5 in. (mm)	L6 in. (mm)	L7 in. (mm)	L8 in. (mm)	D1 in. (mm)	D2 in. (mm)	D3 in. (mm)	D4 in. (mm)	D5 in. (mm)	Mass lbs. (kg.)
<b>XLR6-150</b>	16.1 (410)	9.1 (231)	7.0 (179)	0.75 (19)	0 (0)	0.39 (10)	3.5 (90)	2.8 (70)	2.0 (50)	3.5 (90)	1.5 (38)	2.0 (50)	0.35 (9)	9.3 (4,2)
<b>XLR12-150</b>	18.9 (480)	11.2 (285)	7.7 (195)	0.71 (18)	0.60 (15)	0.47 (12)	4.3 (110)	3.3 (85)	3.0 (75)	3.5 (90)	2.2 (57)	3.1 (80)	0.43 (11)	24.3 (11)
<b>XLR12-200</b>	20.9 (530)	11.2 (285)	9.6 (245)	0.71 (18)	0.60 (15)	0.47 (12)	4.3 (110)	3.3 (85)	3.0 (75)	3.5 (90)	2.2 (57)	3.1 (80)	0.43 (11)	24.3 (11)
<b>XLR25-200</b>	24.4 (620)	14.6 (370)	9.8 (250)	0.79 (20)	0.71 (18)	0.47 (12)	5.3 (135)	4.1 (105)	3.5 (90)	4.3 (110)	2.8 (72)	4.0 (100)	0.6 (14)	44.1 (20)
<b>XLR25-270</b>	27.2 (690)	14.6 (370)	12.6 (320)	0.79 (20)	0.71 (18)	0.47 (12)	5.3 (135)	4.1 (105)	3.5 (90)	4.3 (110)	2.8 (72)	4.0 (100)	0.6 (14)	55.1 (25)
<b>XLR50-275</b>	33.7 (855)	20.5 (520)	13.2 (335)	1.0 (25)	0.79 (20)	0.60 (15)	6.9 (175)	5.5 (140)	4.3 (110)	5.9 (150)	3.4 (87)	4.7 (120)	0.71 (18)	88.2 (40)
<b>XLR50-400</b>	38.6 (980)	20.5 (520)	18.1 (460)	1.0 (25)	0.79 (20)	0.60 (15)	6.9 (175)	5.5 (140)	4.3 (110)	5.9 (150)	3.4 (87)	4.7 (120)	0.71 (18)	88.2 (40)
<b>XLR100-400</b>	53.9 (1370)	35.8 (910)	18.1 (460)	1.0 (25)	0.79 (20)	0.60 (15)	6.9 (175)	5.5 (140)	4.3 (110)	5.9 (150)	3.4 (87)	4.7 (120)	0.71 (18)	143.3 (65)
<b>XLR100-600</b>	61.8 (1570)	35.8 (910)	26.0 (660)	1.0 (25)	0.79 (20)	0.60 (15)	6.9 (175)	5.5 (140)	4.3 (110)	5.9 (150)	3.4 (87)	4.7 (120)	0.71 (18)	143.3 (65)
<b>XLR150-800</b>	103.9 (2640)	70.1 (1780)	33.9 (860)	1.0 (25)	0.79 (20)	0.60 (15)	6.9 (175)	5.5 (140)	4.3 (110)	5.9 (150)	3.4 (87)	4.7 (120)	0.71 (18)	253.5 (115)

Rear Flange Mounting - Fa on Request.

# Jarret Shock Absorbers

## XLR Series

XLR6-150 → XLR-800 Series

### Based On

- Impact velocity : 2 m/s
- Operating temperature : - 20° to + 40°C
- Surface protection : Electrolytic zinc & Painting
- Dynamic performance diagram

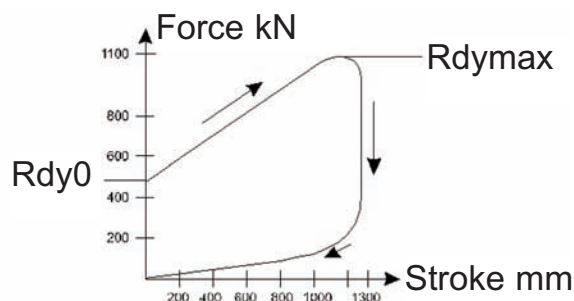

### Symbols:

En = Energy Capacity  
 C = Maximum Stroke  
 Rdy = Dynamic Reaction

### 1 - Energy Calculation

$$E = \frac{1}{2} M_e V_e^2$$

### 2 - Allowable Impact Velocity

$$F < 8 \times \frac{E_n}{E} \text{ Impacts/hour}$$

### 3 - Required Stroke Calculation

$$C_e = C \left( \sqrt{\frac{E}{E_n (0,027 V + 0,22)}} + 1,83 - 1,35 \right)$$

## Application Worksheet

### 4 - Calculation of Effective Reaction Rdy<sub>e</sub>

$$Rdy_e = \left[ \left( \frac{Rdy_{max} - Rdy_0}{C} \right) \times C_e + Rdy_0 \right] (0,1V + 0,8)$$

### 5 - Application Example

**Data:** Effective mass = 75 t  
 Effective impact speed = 2,7 m/s  
 Maximum allowable structural force: 650 kN

- 1: BCLR400 selected
- 2: Energy dissipated/impact is 274 kJ
- 3: Maximum allowable impact frequency  
 $8 \times 400 / 274 = 12$  (10 impacts/hour is acceptable)
- 4: Effective stroke:

$$C_e = 850 \times \left( \sqrt{\frac{274}{400 (0,027 \times 2,7 + 0,22)}} + 1,83 - 1,35 \right)$$

$C_e = 587 \text{ mm}$

$$5: Rdy_e = 520 (0,1 \times 2,7 + 0,8) = 556 \text{ kN}$$

(which is less than maximum allowable reaction force of 650 kN)

Compare with standard performance characteristics:

En = 400 kJ, C = 850 mm,  
 Rdy<sub>max</sub> = 600 kN  
 Rdy<sub>0</sub> = 330 kN

**All performance characteristics can be modified.  
 Please advise us of your specific requirements.**

BCLR-100 → BCLR-1000 Series

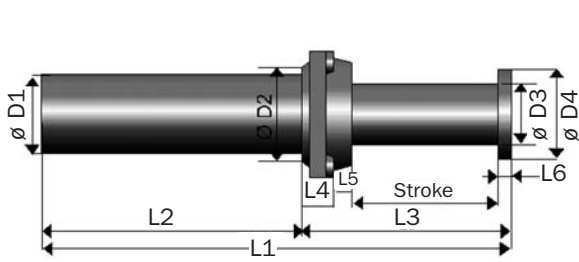

XLR Series - Front Flange Mount - Fc

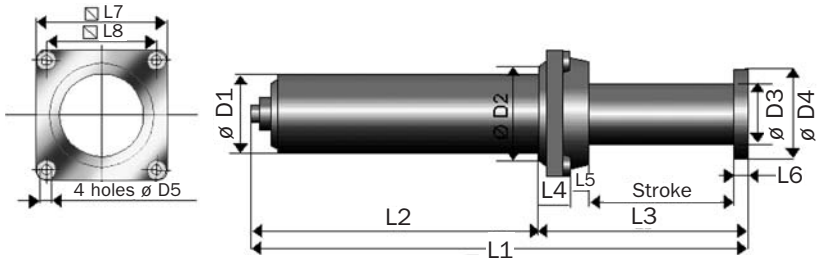

BCLR Series - Front Flange Mount - Fc

Catalog No./ Model	Max Energy Capacity in-lbs. (kJ)	Stroke in. (mm)	Return Force		Rdy0 lbs. (kN)	Rdymax Max Shock Force lbs. (kN)
			Extension lbs. (kN)	Compression lbs. (kN)		
BCLR-100	885,075 (100)	15.7 (400)	6,744 (30,0)	36,403 (161,9)	42,714 (190)	69,691 (310)
BCLR-150	1,327,612 (150)	19.7 (500)	9,330 (41,5)	47,300 (201,4)	44,962 (200)	85,427 (380)
BCLR-220S	1,947,614 (220)	15.7 (400)	10,105 (45,0)	60,698 (270,0)	85,427 (380)	153,944 (685)
BCLR-250	2,212,686 (250)	25.6 (650)	10,116 (45,0)	56,877 (253,0)	60,698 (270)	110,156 (490)
BCLR-400	3,540,298 (400)	33.5 (850)	11,144 (49,6)	69,214 (307,9)	74,187 (330)	134,885 (600)
BCLR-600	5,310,477 (600)	41.3 (1050)	10,678 (47,5)	79,020 (351,5)	83,179 (370)	166,359 (740)
BCLR-800	7,080,597 (800)	47.2 (1200)	14,433 (64,2)	99,141 (441,0)	96,668 (430)	193,336 (860)
BCLR-1000	8,850,746 (1000)	51.2 (1300)	19,109 (85,0)	120,048 (534,0)	112,405 (500)	224,809 (1000)

Impact Speed: Types XLR and BCLR Series shock absorbers are designed for impact velocities of up to 2 m/sec. Higher impact velocities require custom modification.

Catalog No./ Model	L1 in. (mm)	L2 in. (mm)	L3 in. (mm)	L4 in. (mm)	L5 in. (mm)	L6 in. (mm)	L7 in. (mm)	L8 in. (mm)	D1 in. (mm)	D2 in. (mm)	D3 in. (mm)	D4 in. (mm)	D5 in. (mm)	Mass lbs. (kg.)
BCLR-100	44.1 (1120)	26.0 (660)	18.1 (460)	1.0 (25)	0.79 (20)	0.60 (15)	6.9 (175)	5.5 (140)	5.1 (130)	5.9 (150)	4.3 (110)	5.5 (140)	0.71 (18)	139.0 (63)
BCLR-150	53.1 (1350)	30.5 (775)	22.6 (575)	1.2 (30)	1.0 (25)	0.79 (20)	8.5 (215)	6.7 (170)	5.5 (140)	7.3 (185)	4.7 (120)	5.9 (150)	0.87 (22)	198.4 (90)
BCLR-220S	49.5 (1258)	30.8 (783)	18.7 (475)	1.2 (30)	1.0 (25)	0.79 (20)	8.5 (215)	6.7 (170)	5.5 (140)	7.3 (185)	4.7 (120)	5.9 (150)	0.87 (22)	220.5 (100)
BCLR-250	68.9 (1750)	40.4 (1025)	28.5 (725)	1.2 (30)	1.0 (25)	0.79 (20)	8.5 (215)	6.7 (170)	6.1 (155)	7.3 (185)	6.9 (135)	6.7 (170)	0.87 (22)	297.6 (135)
BCLR-400	86.0 (2185)	49.2 (1250)	36.8 (935)	1.4 (35)	1.0 (25)	1.0 (25)	10.4 (265)	8.3 (210)	6.9 (175)	9.3 (235)	5.9 (150)	7.5 (190)	1.1 (27)	480.6 (218)
BCLR-600	100.6 (2555)	55.9 (1420)	44.7 (1135)	1.4 (35)	1.0 (25)	1.0 (25)	10.4 (265)	8.3 (210)	7.9 (200)	9.3 (235)	6.9 (175)	8.5 (215)	1.1 (27)	650.4 (295)
BCLR-800	115.6 (2935)	64.2 (1630)	51.4 (1305)	1.6 (40)	1.4 (35)	1.2 (30)	11.8 (300)	9.4 (240)	8.7 (220)	10.6 (270)	7.5 (190)	9.3 (235)	1.2 (30)	926 (420)
BCLR-1000	127.0 (3225)	71.7 (1820)	55.3 (1405)	1.6 (40)	1.4 (35)	1.2 (30)	11.8 (300)	9.4 (240)	9.1 (230)	10.6 (270)	8.1 (205)	9.8 (248)	1.2 (30)	1036.2 (470)

Rear Flange Mounting - Fa on Request.

# Jarret Shock Absorbers

## BCLR Series

BCLR-100 → BCLR-1000 Series

### Based On

- Impact velocity : 2 m/s
- Operating temperature : - 20° to + 40°C
- Surface protection : Electrolytic zinc & Painting
- Dynamic performance diagram

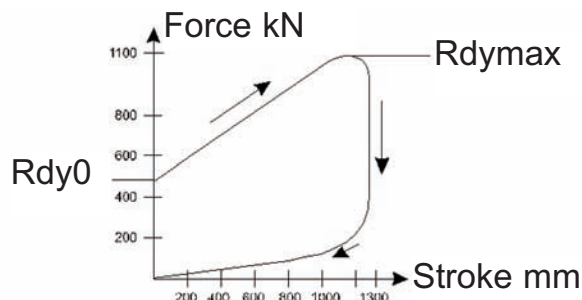

### Symbols:

En = Energy Capacity  
 C = Maximum Stroke  
 Rdy = Dynamic Reaction

### 1 - Energy Calculation

$$E = \frac{1}{2} M_e V_e^2$$

### 2 - Allowable Impact Velocity

$$F < 8 \times \frac{E_n}{E} \text{ Impacts/hour}$$

### 3 - Required Stroke Calculation

$$C_e = C \left( \sqrt{\frac{E}{E_n (0,027 V + 0,22)}} + 1,83 - 1,35 \right)$$

## Application Worksheet

### 4 - Calculation of Effective Reaction Rdy<sub>e</sub>

$$Rdy_e = \left[ \left( \frac{Rdy_{max} - Rdy_0}{C} \right) \times C_e + Rdy_0 \right] (0,1V + 0,8)$$

### 5 - Application Example

**Data:** Effective mass = 75 t  
 Effective impact speed = 2,7 m/s  
 Maximum allowable structural force: 650 kN

- 1: BCLR400 selected
- 2: Energy dissipated/impact is 274 kJ
- 3: Maximum allowable impact frequency  
 $8 \times 400 / 274 = 12$  (10 impacts/hour is acceptable)
- 4: Effective stroke:

$$C_e = 850 \times \left( \sqrt{\frac{274}{400 (0,027 \times 2,7 + 0,22)}} + 1,83 - 1,35 \right)$$

$C_e = 587 \text{ mm}$

$$5: Rdy_e = 520 (0,1 \times 2,7 + 0,8) = 556 \text{ kN}$$

(which is less than maximum allowable reaction force of 650 kN)

Compare with Standard  
 Performance characteristics are:  
 En = 400 kJ, C = 850 mm,  
 Rdy<sub>max</sub> = 600 kN  
 Rdy<sub>0</sub> = 330 kN

**All performance characteristics can be modified.  
 Please advise us of your specific requirements.**





### Applications:

- Control of bridge cranes
- Trolley platforms
- Large container transfer
- Automated aisle stacker cranes
- Cab operated bridge cranes
- Ship to shore container cranes
- Overhead bridge cranes
- Gantry cranes
- Ship to shore container cranes
- Transportation end stops



HEAVY INDUSTRY PRODUCTS

## **Enidine USA**

**Industrial/Rail Headquarters  
Enidine Incorporated**  
7 Centre Drive  
Orchard Park, New York 14127  
USA  
Phone: 716-662-1900  
Fax: 716-662-1909  
Email: [industrialsales@enidine.com](mailto:industrialsales@enidine.com)  
Email: [railsales@enidine.com](mailto:railsales@enidine.com)  
[www.enidine.com](http://www.enidine.com)

**Enidine West  
Enidine Incorporated**  
184 Technology Dr.,  
Suite 201  
Irvine, California 92618  
USA  
Phone: 949-727-9112  
Fax: 949-727-9107  
Email: [industrialsales@enidine.com](mailto:industrialsales@enidine.com)  
[www.enidine.com](http://www.enidine.com)

## **Enidine Europe**

**Enidine Trading Company GmbH**  
Rheinauenstrasse 5  
79415 Bad Bellingen  
Rheinweiler  
Germany  
Phone: 49 7635 82648 0  
Fax: 49 7635 82648 29  
Email: [info@enidine.de](mailto:info@enidine.de)  
[www.enidine-europe.com](http://www.enidine-europe.com)

**Enidine / Jarret**  
14-38, rue Alexandre, Bat E2  
BP35  
Gennevilliers, CEDEX, 92234  
France  
Phone: 33 1 41 32 26 60  
Fax: 33 1 40 86 12 82  
Email: [info@enidine.de](mailto:info@enidine.de)  
Email: [contact@jarret.fr](mailto:contact@jarret.fr)  
[www.enidine-europe.com](http://www.enidine-europe.com)  
[www.jarret.fr](http://www.jarret.fr)

## **Enidine Japan**

**Enidine Co. Ltd.**  
4-5-24 Chigasaki-Higashi, Tsuzuki-Ku  
Yokohama-Shi  
Kanagawa 224-0033  
Japan  
Phone: 81 45 947 1671  
Fax: 81 45 945 3967  
Email: [support@enidine.co.jp](mailto:support@enidine.co.jp)  
[www.enidine.co.jp](http://www.enidine.co.jp)

## **Enidine China**

**Enidine Hangzhou**  
3rd. Floor, No. 1 Building South Area  
No. 98, 19 Street  
Hangzhou Economic & Technological  
Development Zone  
Hangzhou, China 310018  
Phone: 86 571 8671 4399  
Fax: 86 571 8671 4055  
Email: [tobby@enidine.cn](mailto:tobby@enidine.cn)  
[www.enidine.cn](http://www.enidine.cn)

# Heavy Industry Products

Energy Absorption • Vibration Isolation • Motion Control

# ENIDINE

An **IMC** Company

Solutions in Energy Absorption and Vibration Isolation

IND555R1 7.5M 04/07